

IMCOPIPES FZ LLC

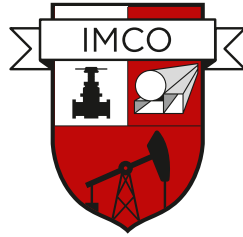

We serve the world

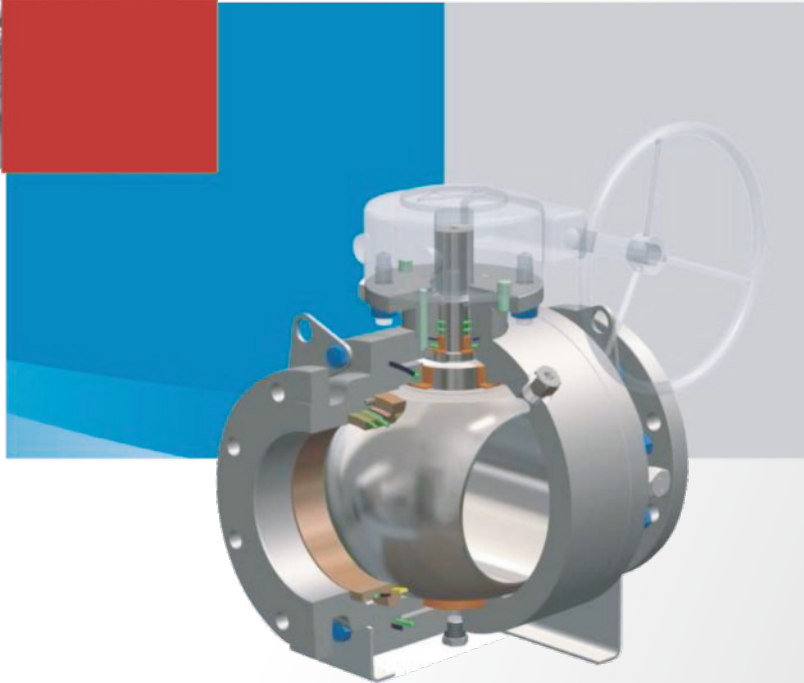

Ball Valve Series

www.imcopipes.com

Contents

Ordering Guide	3
Trunnion Pipeline Ball Valve	5
Forged Steel Trunnion Ball Valve	7
Cast Steel Trunnion Ball Valve	17
Floating Ball Valve	22
2PCS Body Floating Ball Valve	24
1PC Body Floating Ball Valve	30
3PCS Body Floating Ball Valve	32
Double Block And Bleed Valve (Twin Ball Design)	35
Forged Steel Top Entry Ball Valve	38
Cast Steel Top Entry Ball Valve	40
Cryogenic Ball Valve	43
Metal Seated Ball Valve	46
Fully Welled Ball Valve	49
Flange Dimensions	52
Cv Value	58
Torque Value	59
Torque Value & Mounting Flange Dimensions	60
Soft Materials Data	62

Ordering Guide

Example

12	-	C	F	9	4	1	T	-	R	G	-	11111
1		2	3	4	5	6	7		8	9		10

1. Valve Size

NPS	1/2"	3/4"	1"	1 1/2"	2"	2 1/2"	3"	4"	5"	6"	8"	10"	12"
DN	15	20	25	40	50	65	80	100	125	150	200	250	300
Symbol	1/2	3/4	1	1 1/2	2	2 1/2	3	4	5	6	8	10	12
NPS	14"	16"	18"	20"	22"	24"	26"	28"	30"	32"	34"	36"	40"
DN	350	400	450	500	550	600	650	700	750	800	850	900	1000
Symbol	14	16	18	20	22	24	26	28	30	32	34	36	40

2. Body/Tailpiece Material Type

Symbol	Type
C	Cast Steel
F	Forged Steel

3. Bore Type

Symbol	Type
F	Full Bore
R	Reduce Bore

4. Valve Type

Symbol	Type
9	3-PC Ball Valve
8	2-PC Ball Valve
7	1-PC Ball Valve
6	Fully Welded Ball Valve
5	Top Entry Ball Valve

5. Body/Tailpiece Material

Material	Cast	CF8	CF3	CF3M	WCB	CF8M	LCB	4A	5A	6A	Others
	Forged	F304	F304L	F316L	A105	F316	LF2	F51	F53	F55	
Symbol		1	2	3	4	5	6	7	8	9	O

6. Nominal Pressure

Class	150	300	600	800	900	1500	2500
Symbol	1	3	6	8	9	15	25

7. Body Type

Symbol	Type
T	Trunnion Ball
F	Floating Ball

9. Valve Operation

Type	Lever	Gear	Bare Stem	Others
Symbol	L	G	B	O

8. End Type

Symbol	Type
R	Raised Face Flange
J	Ring Joint Flange
F	Flat Face Flange
B	Butt-Welding End
S	Socket Welding End
N	Screwed End
SN	Socket Welding End / Screwed End
W	Wafer
G	Grayloc-Hub End

10. Trim Material

Symbol	Ball	Symbol	Stem	Symbol	Seat Ring	Symbol	Seat Insert	Symbol	O Ring
1	A105N+ENP	1	A105N+ENP	1	A105N+ENP	1	PTFE	1	Viton A
2	F6a	2	F6a	2	F6a	2	RPTFE	2	Viton B
3	F304	3	F304	3	F304	3	Devlon	3	HNBR
4	F304L	4	F304L	4	F304L	4	PEEK	4	AED Viton
5	F316	5	F316	5	F316	5	Nylon 12	5	Viton GLT
6	F316L	6	F316L	6	F316L	6	Nylon 1010	6	AED Viton GLT
7	F51	7	F51	7	F51	7	PCTFE	7	AED HNBR
8	17-4PH	8	17-4PH	8	17-4PH	8	Molon	8	Lip Seal
9	AISI4140+ENP	9	AISI4140+ENP	9	AISI4140+ENP	9	Delrin	9	Elast-O-Lion
A	LF2+ENP	A	LF2+ENP	A	LF2+ENP	A	Viton	A	Aflas
B	A105N+TC	B	17-4PH+ENP	B	A105N+TC	B	PFA	B	Viton Extreme
C	F316+TC	C	F51+ENP	C	F316+TC	C	POM	C	Kalrez
O	Others	O	Others	O	Others	O	Others	O	Others

TRUNNION PIPELINE BALL VALVE SERIES



Trunnion Pipeline Ball Valve

◆ Usage

The trunnion ball valve is available from Class 150 to Class 2500. It is an isolation valve used to shut off or connect the media in pipelines. The valves are available in a wide variety of materials that should be selected depending on the application. Typically these valves are used with media such as water, steam, oil, liquefied gas, natural gas, coal gas, nitric acid, oxidizer, urea etc. Operation may be by manual lever, manual worm gear box, pneumatic, hydraulic and electric actuation. End connections are available flanged, hub end and butt weld ends.

◆ Structural Features

1. Double Block and Bleed (DBB)

When the valve is in the closed position and the centre cavity is emptied via the discharge valve (bleed), both the upstream and downstream seats independently block the media (double block). The central discharge valve also allows each seat to be independently checked during pressure testing and allows deposits inside the body to be washed out to reduce the chance of seat damage caused by trapped impurities.

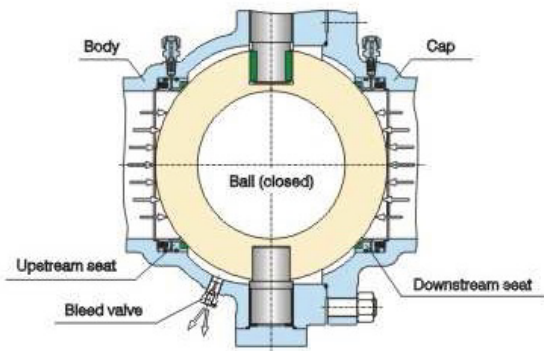

2. Low Operating Torque

The trunnion design incorporates precision aligned top and bottom trunnions around which the ball pivots while the spring assisted seats can move in and out against the ball. This results in low operating torque even under operating pressures. The standard design uses self-lubricating PTFE and metal sliding bearings and a finely polished stem to achieve the lowest friction coefficient while maintaining high integrity.

3. Emergency Sealing Device

Valves of nominal size 6" (DN150) and greater are designed with emergency sealant injection devices located at the stem and seats. If the seats or stem o-ring is damaged due to misuse or accident then the specified sealant can be forcibly injected to effectively stop leakage past the seats or stem o-ring. These injection devices may also be used for washing and lubricating the valve as part of preventative maintenance.

Sealant Injection Device

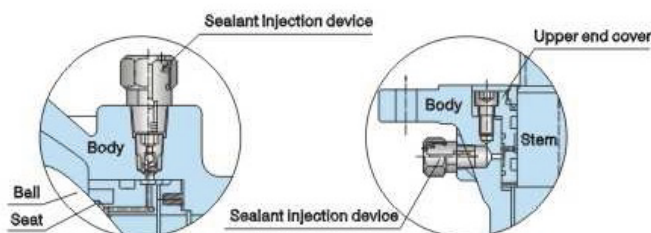

4. Fire Safe Structure Design

In case of fire during the use of the valve the soft components such as the seat ring inserts, stem o-rings, body o-rings etc. which may be made of PTFE, rubber and other elastomers can become damaged due to the high temperatures. In this instance the metal seat rings which have a specially designed geometry with move towards the ball and effectively make a metal to metal seal to control leakage that would otherwise occur. The fire safe design of trunnion pipeline ball valves conforms to the requirements of API 607, API 6FA, BS 6755 and other industry standards.

Fire Safe Structure of seat

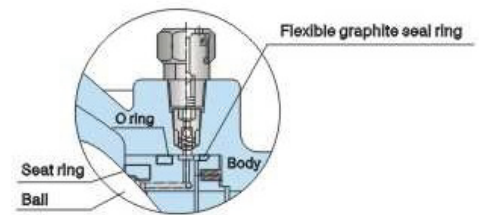

Normal use

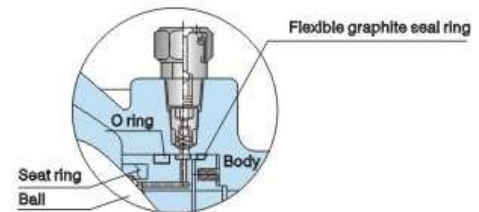

After burning

Fire Safe Structure of Middle Flange

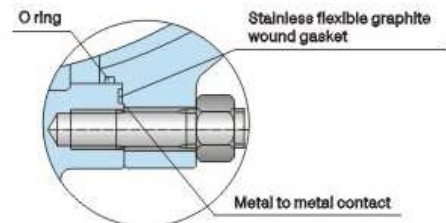

Fire Safe Structure Design of Stem

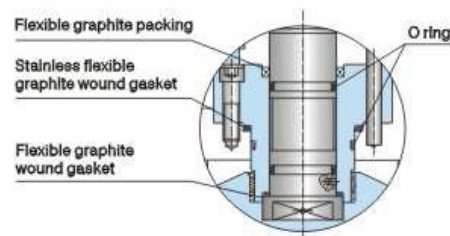

5. Anti-static Design

The antistatic design ensures that no differential electrical potential can build up across or within the valve when operating in any position or being opened and closed, thus avoiding the potential of a static discharge spark that could cause a fire. To achieve this, the ball and stem, seat ring and body parts must be electrically continuous. This is achieved by ensuring that wherever soft components such as o-rings, gaskets and seat inserts are used they cannot totally insulate or isolate the metal parts from one another; electrical continuity is achieved via other metallic components staying in contact.

6. Reliable Seat Sealing Structure

The seat sealing is realized through two floating seat retainers. They can float axially to block the fluid, including ball sealing and body sealing. The low pressure sealing of valve seat is realized by spring pre-tightening. In addition, the piston effect of valve seat is designed reasonably, which realizes high pressure sealing by the pressure of the medium itself. The following two kinds of ball sealing can be realized.

7. Single Sealing

(Automatic Pressure Relief in Middle Cavity of Valve)

Generally, the single sealing structure is used, that is, there is only the upstream sealing. As the independent spring loaded upstream and downstream sealing seats are used, the over-pressure inside valve cavity can overcome the pre-tightening effect of the spring, so as to make the seat release from the ball and realize automatic pressure relief towards the downstream part. The upstream side: When the seat moves axially along the valve, the pressure P exerted on the upstream part (inlet) produces a reverse force on A1, As A2 is higher than A1, $A2 - A1 = B1$, the force on B1 will push the seat to the ball and realize tight sealing of the upstream part.

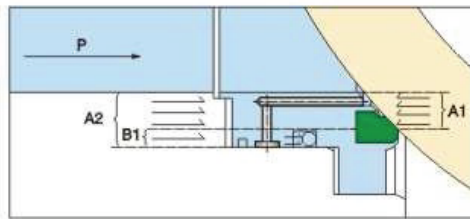

A2 > A1

The downstream side: Once the pressure Pb inside the valve cavity increases, the force exerted on A3 is higher than that on A4. As $A3 - A4 = B2$, the pressure differential on B2 will overcome the spring force to make the seat release from the ball and realize pressure relief of valve cavity to the downstream part. Afterwards, the seat and ball will be sealed under the spring action.

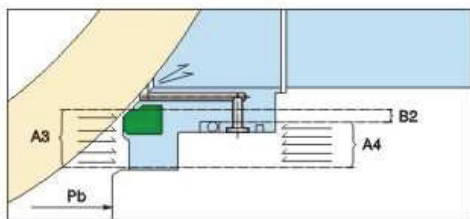

A3 > A4

8. Double Sealing (Double Piston)

The trunnion pipeline ball valve can be designed with the double sealing structure before and after the ball for some special service conditions and user requirements. It has double piston effect. Under normal condition, the valve generally adopts primary sealing. When the primary seat sealing was damaged and causes leakage, the secondary seat can play the function of sealing and enhance the sealing reliability. The seat adopts the combined structure. The primary seal is metal to metal seal. The secondary seal is fluorine rubber O ring that can ensure the ball valve can reach the bubble level sealing. When the pressure differential is very low, the sealing seat

will press the ball through the spring action to realize primary sealing. When the pressure differential rises, the sealing force of seat and body will increase accordingly so as to tightly seal the seat and ball and ensure good sealing performance. Primary sealing: Upstream. When the pressure differential is lower or there is no pressure differential, the floating seat will move axially along the valve under the spring action and push the seat towards the ball to keep tight sealing. When the pipeline pressure P increases, the force exerted in the area A2 of valve seat is higher than the force exerted on the area A1, $A2 - A1 = B1$. Therefore, the force in B1 will push the seat towards the ball and realize tight sealing of the upstream part.

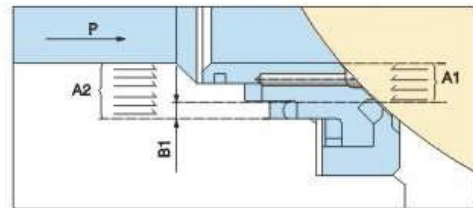

A2 > A1

Secondary sealing: Downstream. When the pressure differential is lower or there is no pressure differential, the floating seat will move axially along the valve under the spring action and push the seat towards the ball to keep tight sealing. When the valve cavity pressure P increases, the force exerted on the area A4 of valve seat is higher than the force exerted on the area A3, $A4 - A3 = B2$. Therefore, the force on B2 will push the seat towards the ball and realize tight sealing of the upstream part.

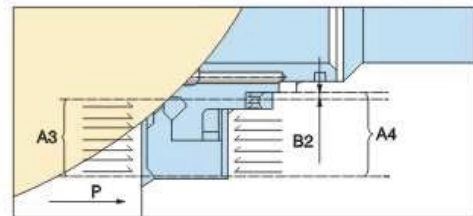

A4 > A3

9. Anti Blow-Out Stem

The stem adopts the blow-out proof structure. The stem is designed with the footstep at its bottom so that with the positioning of upper end cover and screw, the stem will not be blown out by the medium even in case of abnormal pressure rise in the valve cavity.

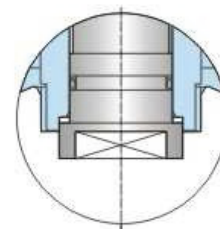

Blow-out proof stem

Forged Steel Trunnion Ball Valve

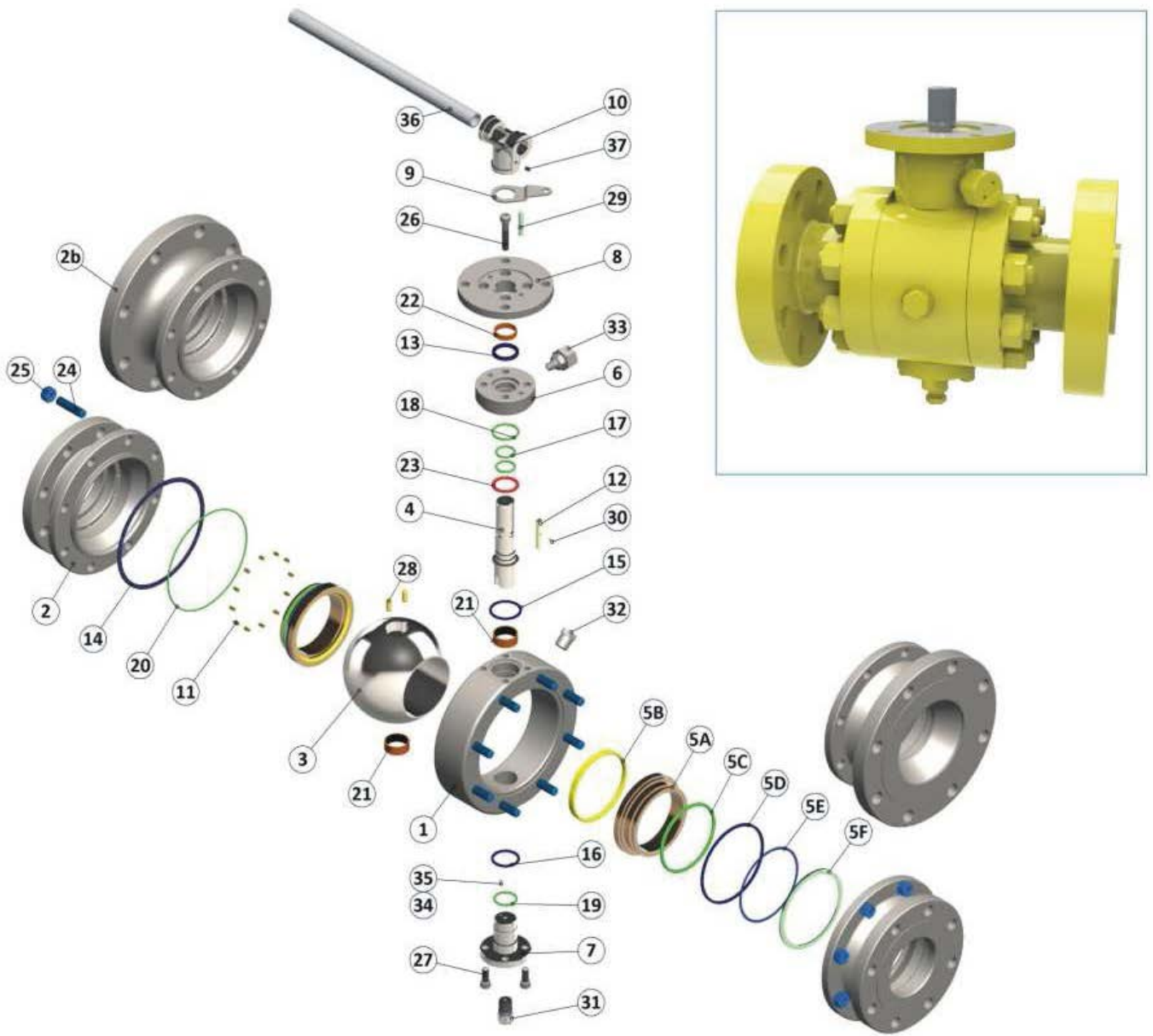

◆ **Forged Steel Trunnion Ball Valve With Post Trunnion**

1	2	2b	3	4	5A	5B	5C	5D	5E	5F	6	7	8	9
Body	Tailpiece	RB Tailpiece	Ball	Stem	Seat Ring	Seat Insert	O-Ring	Seat Fire Safe Seal	Back-Up Ring	Seat Plate	Gland	Post Trunnion	Gland Plate	Locking Plate
10	11	12	13	14	15	16	17	18	19	20	21	22	23	24
Handle Guide	Seat Spring	Key	Stem Packing	Body Fire Safe Seal	Gland Fire Safe Seal	Trunnion Fire Safe Seal	Stem O-Ring	Gland O-Ring	Trunnion O-Ring	Body O-Ring	DU Bearing	DU Bearing	Stem Thrust Bearing	Body Studs
25	26	27	28	29	30	31	32	33	34	35	36	37		
Body Nuts	Gland Bolt	Trunnion Bolt	Parallel Pins	Parallel Pins	Spring Pins	Vent Valve	Plug	Stem Injection Fitting	Anti-Static Ball	Anti-Static Spring	Pipe	Handle Screw		

◆ Part Materials and Main Parameters

Item	Part	ASME Class	Standard (Nace)	Low Temp (Nace)	Stainless Steel (Nace)
1	Body	All	A105	A350 LF2	A182 Gr.316
2	Tailpiece	All	A105	A350 LF2	A182 Gr.316
2b	RB Tailpiece	All	A105	A350 LF2	A182 Gr.316
3	Ball	150 through 900	A105 + ENP	A350 LF2 + ENP	A182 Gr.316
		1500 & 2500	4130/4140 + ENP	4130/4140 + ENP	A564 Type 630
4	Stem	150 through 900	4130/4140 + ENP	4130/4140 + ENP	A182 Gr.316
		1500 & 2500	4130/4140 + ENP	4130/4140 + ENP	A564 Type 630
5A	Seat Ring	150 through 2500	A105+ENP	A350 LF2+ENP	A182 Gr.316
5B	Seat Insert	150 through 300	Filled PTFE	Filled PTFE	Filled PTFE
		600 through 2500	Nylon / Devlon / PEEK	Nylon / Devlon / PEEK	Nylon / Devlon / PEEK
5C	O-Ring	All	HNBR / FKM	HNBR / FKM	HNBR / FKM
5D	Seat Fire Safe Seal	All	Graphite	Graphite	Graphite
5E	Back-Up Ring	All	PTFE	PTFE	PTFE
5F	Seat Plate	All	A105+ENP	A350 LF2+ENP	A182 Gr.316
6	Gland	All	A105	A350 LF2	A182 Gr.316
7	Post Trunnion	All	A105	A350 LF2	A182 Gr.316
8	Gland Plate	All	A105	A350 LF2	A182 Gr.316
9	Locking Plate	All	Carbon Steel+Zn	Carbon Steel+Zn	Stainless Steel
10	Handle Guide	All	A216 Gr.WCB	A216 Gr.WCB	A216 Gr.WCB+Zn
11	Seat Spring	All	Inconel X750	Inconel X750	Inconel X750
12	Key	All	Carbon Steel	Carbon Steel	Stainless Steel
13	Stem Packing	All	Graphite	Graphite	Graphite
14	Body Fire Safe Seal	All	Spiral Wound Gasket	Spiral Wound Gasket	Spiral Wound Gasket
15	Gland Fire Safe Seal	All	Spiral Wound Gasket	Spiral Wound Gasket	Spiral Wound Gasket
16	Trunnion Fire Safe Seal	All	Spiral Wound Gasket	Spiral Wound Gasket	Spiral Wound Gasket
17	Stem O-Ring	All	HNBR / FKM	HNBR / FKM	HNBR / FKM
18	Gland O-Ring	All	HNBR / FKM	HNBR / FKM	HNBR / FKM
19	Trunnion O-Ring	All	HNBR / FKM	HNBR / FKM	HNBR / FKM
20	Body O-Ring	All	HNBR / FKM	HNBR / FKM	HNBR / FKM
21	DU Bearing	All	CS + Filled PTFE	SS + Filled PTFE	SS + Filled PTFE
22	DU Bearing	All	CS + Filled PTFE	SS + Filled PTFE	SS + Filled PTFE
23	Stem Thrust Bearing	All	CS + Filled PTFE	SS + Filled PTFE	SS + Filled PTFE
24	Body Studs	All	A193 Gr.B7M	A193 Gr.L7M	A193 Gr.B8M
25	Body Nuts	All	A194 Gr.2HM	A194 Gr.7M	A194 Gr.8M
26	Gland Bolt	All	A193 Gr.B7M	A193 Gr.L7M	A193 Gr.B8M
27	Trunnion Bolt	All	A193 Gr.B7M	A193 Gr.L7M	A193 Gr.B8M
28	Parallel Pins	All	AISI 1045	AISI 1045	Stainless Steel
29	Parallel Pins	All	AISI 1045	AISI 1045	Stainless Steel
30	Spring Pins	All	AISI 1566	AISI 1566	AISI 1566
31	Vent Valve	All	A105+Zn (Main Material)	A276 Gr.316	A276 Gr.316
32	Plug	All	A276 Gr.316	A276 Gr.316	A276 Gr.316
33	Stem Injection Fitting	All	A105+Zn (Main Material)	A276 Gr.316	A276 Gr.316
34	Anti-static Ball	All	316 S.S.	316 S.S.	316 S.S.
35	Anti-Static Spring	All	316 S.S.	316 S.S.	316 S.S.
36	Pipe	All	Carbon Steel+Painting	Carbon Steel+Painting	Carbon Steel+Painting
37	Handle Screw	All	Carbon Steel+Painting	Carbon Steel+Painting	Carbon Steel+Painting

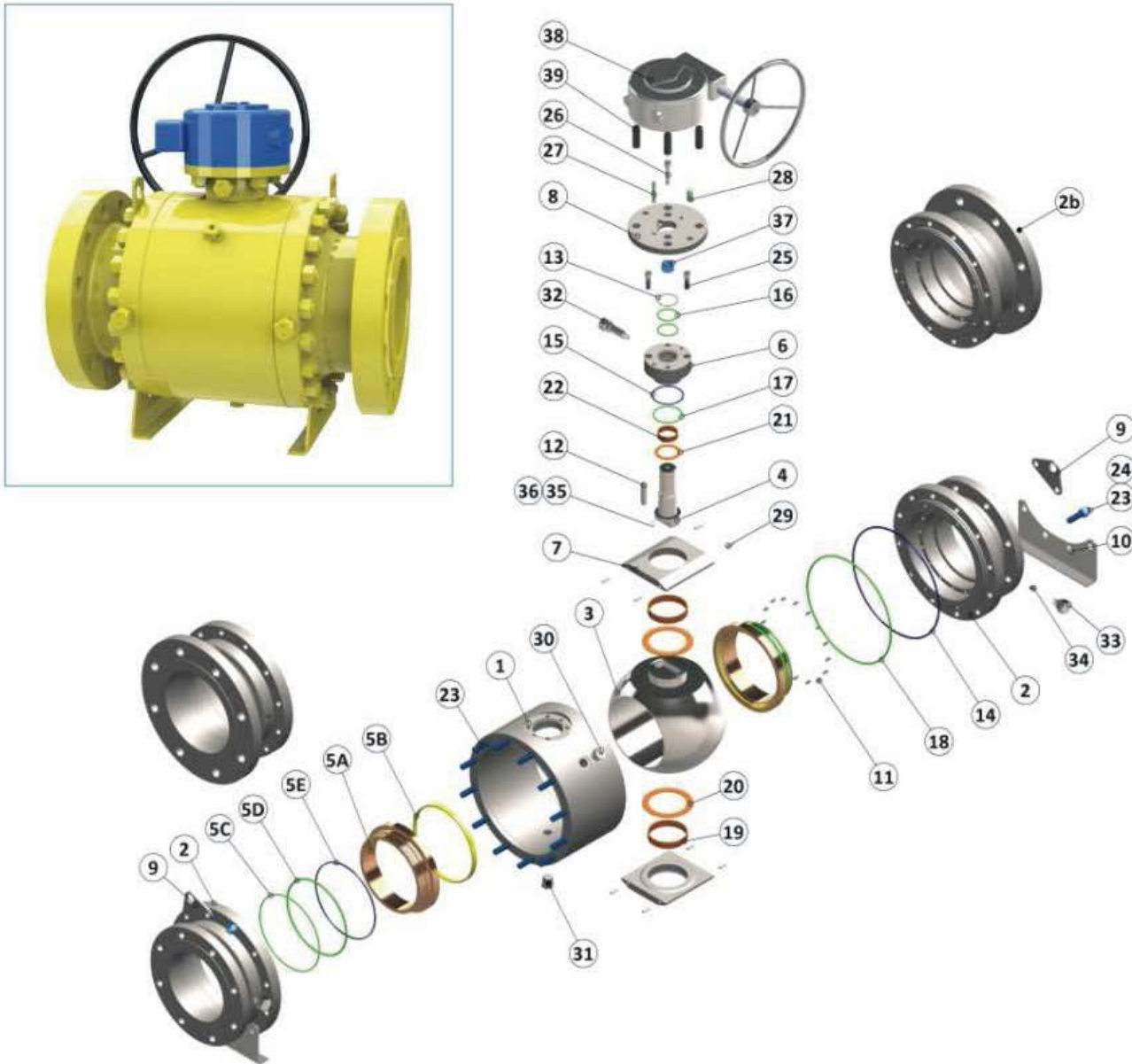

◆ Forged Steel Trunnion Ball Valve With Plate Trunnion

1	2	2b	3	4	5A	5B	5C	5D	5E	6	7	8	9	10
Body	Tailpiece	RB Tailpiece	Ball	Stem	Seat Ring	Seat Insert	O-Ring	O-Ring	Seat Fire Safe Seal	Gland	Plate Trunnion	Gland Plate	Lifting Plate	Leg Plate
11	12	13	14	15	16	17	18	19	20	21	22	23	24	25
Seat Spring	Key	Stem Packing	Body Fire Safe Seal	Gland Fire Safe Seal	Stem O-Ring	Gland O-Ring	Body O-Ring	DU Bearing	DU Thrust Bearing	Stem Thrust Bearing	Stem DU Bearing	Body Studs	Body Nuts	Gland Bolt
26	27	28	29	30	31	32	33	34	35	36	37	38	39	
Gland Plate Bolt	Parallel Pins	Parallel Pins	Parallel Pins	Vent Valve	Plug	Stem Injection Fitting	Seat Injection Fitting	Seat Check Valve	Anti-Static Ball	Anti-Static Spring	Gear Nuts	Gear	Gear Bolts	

◆ Part Materials and Main Parameters

Item	Part	ASME Class	Standard (Nace)	Low Temp (Nace)	Stainless Steel (Nace)
1	Body	All	A105	A350 LF2	A182 Gr.316
2	Tailpiece	All	A105	A350 LF2	A182 Gr.316
2b	RB Tailpiece	All	A105	A350 LF2	A182 Gr.316
3	Ball	150 through 900	A105 + ENP	A350 LF2 + ENP	A182 Gr.316
		1500 & 2500	4130/4140 + ENP	4130/4140 + ENP	A564 Type 630
4	Stem	150 through 900	4130/4140 + ENP	4130/4140 + ENP	A182 Gr.316
		1500 & 2500	4130/4140 + ENP	4130/4140 + ENP	A564 Type 630
5A	Seat Ring	150 through 2500	A105+ENP	A350 LF2+ENP	A182 Gr.316
5B	Seat Insert	150 through 300	Filled PTFE	Filled PTFE	Filled PTFE
		600 through 2500	Nylon / Devlon / PEEK	Nylon / Devlon / PEEK	Nylon / Devlon / PEEK
5C	O-Ring	All	HNBR / FKM	HNBR / FKM	HNBR / FKM
5D	O-Ring	All	HNBR / FKM	HNBR / FKM	HNBR / FKM
5E	Seat Fire Safe Seal	All	Graphite	Graphite	Graphite
6	Gland	All	A105	A350 LF2	A182 Gr.316
7	Plate Trunnion	All	4130/4140 + ENP	4130/4140 + ENP	A182 Gr.316
8	Gland Plate	All	A105	A350 LF2	A182 Gr.316
9	Lifting Plate	All	Carbon Steel	Carbon Steel	Stainless Steel
10	Leg Plate	All	Carbon Steel	Carbon Steel	Stainless Steel
11	Seat Spring	All	Inconel X750	Inconel X750	Inconel X750
12	Key	All	Carbon Steel	Carbon Steel	Stainless Steel
13	Stem Packing	All	Graphite	Graphite	Graphite
14	Body Fire Safe Seal	All	Spiral Wound Gasket	Spiral Wound Gasket	Spiral Wound Gasket
15	Gland Fire Safe Seal	All	Spiral Wound Gasket	Spiral Wound Gasket	Spiral Wound Gasket
16	Stem O-Ring	All	HNBR / FKM	HNBR / FKM	HNBR / FKM
17	Gland O-Ring	All	HNBR / FKM	HNBR / FKM	HNBR / FKM
18	Body O-Ring	All	HNBR / FKM	HNBR / FKM	HNBR / FKM
19	DU Bearing	All	CS + Filled PTFE	SS + Filled PTFE	SS + Filled PTFE
20	DU Thrust Bearing	All	CS + Filled PTFE	SS + Filled PTFE	SS + Filled PTFE
21	Stem Thrust Bearing	All	CS + Filled PTFE	SS + Filled PTFE	SS + Filled PTFE
22	Stem DU Bearing	All	CS + Filled PTFE	SS + Filled PTFE	SS + Filled PTFE
23	Body Studs	All	A193 Gr.B7M	A193 Gr.L7M	A193 Gr.B8M
24	Body Nuts	All	A194 Gr.2HM	A194 Gr.7M	A194 Gr.8M
25	Gland Bolt	All	A193 Gr.B7M	A193 Gr.L7M	A193 Gr.B8M
26	Gland Plate Bolt	All	A193 Gr.B7M	A193 Gr.L7M	A193 Gr.B8M
27	Parallel Pins	All	AISI 1045	AISI 1045	Stainless Steel
28	Parallel Pins	All	AISI 1045	AISI 1045	Stainless Steel
29	Parallel Pins	All	A276 Gr.316	A276 Gr.316	A276 Gr.316
30	Vent Valve	All	A276 Gr.316	A276 Gr.316	A276 Gr.316
31	Plug	All	A276 Gr.316	A276 Gr.316	A276 Gr.316
32	Stem Injection Fitting	All	A105+Zn (Main Material)	Stainless Steel	A276 Gr.316
33	Seat Injection Fitting	All	A105+Zn (Main Material)	Stainless Steel	A276 Gr.316
34	Seat Check Valve	All	A276 Gr.316	A276 Gr.316	A276 Gr.316
35	Anti-static Ball	All	316 S.S.	316 S.S.	316 S.S.
36	Anti-Static Spring	All	316 S.S.	316 S.S.	316 S.S.
37	Gear Nuts	All	A194 Gr.2HM	A194 Gr.7M	A194 Gr.8M
38	Gear	All	A216 Gr.WCB	A216 Gr.WCB	A216 Gr.WCB
39	Gear Bolts	All	A193 Gr.B7M	A193 Gr.L7M	A193 Gr.B8M

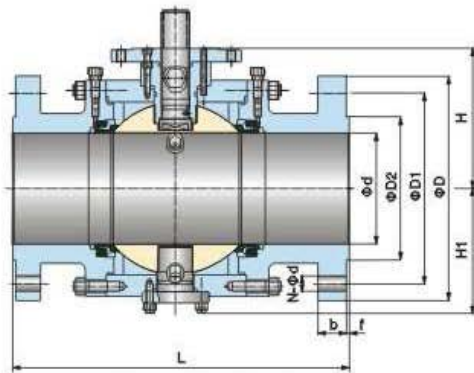

External Supporting Structure

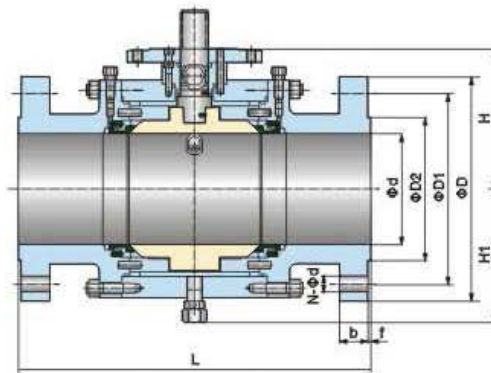

Internal Supporting Structure

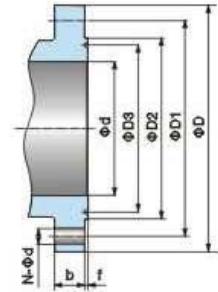

◆ Full Port

Pressure Rating	Nominal Diameter		d	Flange	Butt Welding	Raised Face Flange							General		Support Board		Weight (kg)	
	Class	NPS				DN	L(RF)	L(BW)	D	D1	D2	D3	f	b	N-φd	H	H1	H
150	2"	50	50	178	216	150	120.5	92	/	2	17.5	4-φ19	93	88	/	/	19	/
	3"	80	75	203	283	190	152.5	127	/	2	22.3	4-φ19	118.5	117	/	/	28	/
	4"	100	100	229	305	230	190.5	157	/	2	22.3	8-φ19	143.5	137	/	/	50	/
	6"	150	150	394	457	280	241.5	216	/	2	24	8-φ22	208	178.5	/	/	160	/
	8"	200	201	457	521	345	298.5	270	/	2	27	8-φ22	248	222	248	235	270	284
	10"	250	252	534	559	405	362	324	/	2	29	12-φ25	294	265	294	288	415	436
	12"	300	303	610	635	485	432	381	/	2	30.5	12-φ25	344.5	308.5	345	330	660	693
	14"	350	334	686	762	535	476	413	/	2	33.5	12-φ29	377	334	377	360	890	935
	16"	400	385	762	838	595	540	470	/	2	35	16-φ29	418	375	418	400	1080	1134
	18"	450	436	864	914	635	578	533	/	2	38.5	16-φ32	463	410	463	435	1480	1554
	20"	500	487	914	991	700	635	584	/	2	41.5	20-φ32	502	458	502	484	1970	2069
	24"	600	589	1067	1143	815	749.5	692	/	2	46.5	20-φ35	586	534	586	568	3000	3150
	26"	650	633	1143	1245	870	806.5	749	/	2	68	24-φ35	626	582	626	594	3612	3793
	28"	700	684	1245	1346	927	864	800	/	2	71	28-φ35	644	605	644	658	4402	4622
	30"	750	735	1295	1397	984	914.5	857	/	2	75	28-φ35	720	672	720	677	5112	5368
	32"	800	779	1372	1524	1060	978	914	/	2	81	28-φ41	742	704	742	746	6667	7000
36"	900	874	1524	1727	1168	1086	1022	/	2	90	32-φ41	839	796	839	791	8627	9058	
40"	1000	976	1727	/	1289	1200	1124	/	2	90	36-φ41	913.5	866	913.5	863	12313	12929	
42"	1050	1020	1987	/	1346	1257	1194	/	2	97	36-φ41	943	881	943	937	14000	14700	
48"	1200	1166	2120	/	1511	1422	1359	/	2	108	44-φ41	1097	1016	1097	1066	21470	22544	
300	2"	50	50	216	216	165	127	92	/	2	21	8-φ19	93	88	/	/	22	/
	3"	80	75	283	283	210	168.5	127	/	2	27	8-φ22	118.5	117	/	/	38	/
	4"	100	100	305	305	255	200	157	/	2	30.5	8-φ22	143.5	137	/	/	60	/
	6"	150	150	403	457	320	270	216	/	2	35	12-φ22	208	178.5	/	/	180	189
	8"	200	201	502	521	380	330	270	/	2	40	12-φ25	248	222	248	235	295	310
	10"	250	252	568	559	445	387.5	324	/	2	46.5	16-φ29	29	265	294	288	450	473
	12"	300	303	648	635	520	451	381	/	2	49.5	16-φ32	344.5	308.5	345	330	700	735
	14"	350	334	762	762	585	514.5	413	/	2	52.5	20-φ32	377	334	377	360	1160	1218
	16"	400	385	838	838	650	571.5	470	/	2	56	20-φ35	423	380	423	345	1340	1407
	18"	450	436	914	914	710	628.5	533	/	2	59	24-φ35	463	410	463	431	1610	1691
	20"	500	487	991	991	775	686	584	/	2	62	24-φ35	502	458	502	474	2200	2310
	24"	600	589	1143	1143	915	813	692	/	2	68.5	24-φ41	592	549	592	561	3460	3633
	26"	650	633	1245	1245	972	876.5	749	/	2	84	28-φ45	633	590	633	601	4017	4218
	28"	700	684	1346	1346	1035	940	800	/	2	91	28-φ45	680	737	680	736	4974	5223
	30"	750	735	1397	1397	1092	997	857	/	2	96	28-φ48	730	682	730	684	5681	5965
	32"	800	779	1524	1524	1149	1054	914	/	2	100	28-φ51	765	720	765	716	6837	7179
36"	900	874	1727	1727	1270	1168	1022	/	2	112	32-φ54	847	804	847	798	8700	9135	
40"	1000	976	1930	/	1238	1156	1086	/	2	114	32-φ45	921	877	921	971	12299	12914	
42"	1050	1020	2032	/	1289	1206.5	1137	/	2	119	32-φ45	936	900	936	890	14379	15098	
48"	1200	1166	2170	/	1467	1372	1302	/	2	134	32-φ51	1093	1052	1093	1040	21482	22556	

Note: The weight value is only for flanged valve. Please consult our factory for higher nominal diameter or weight. Any modification to size H, H1, and weight will not be notified otherwise.

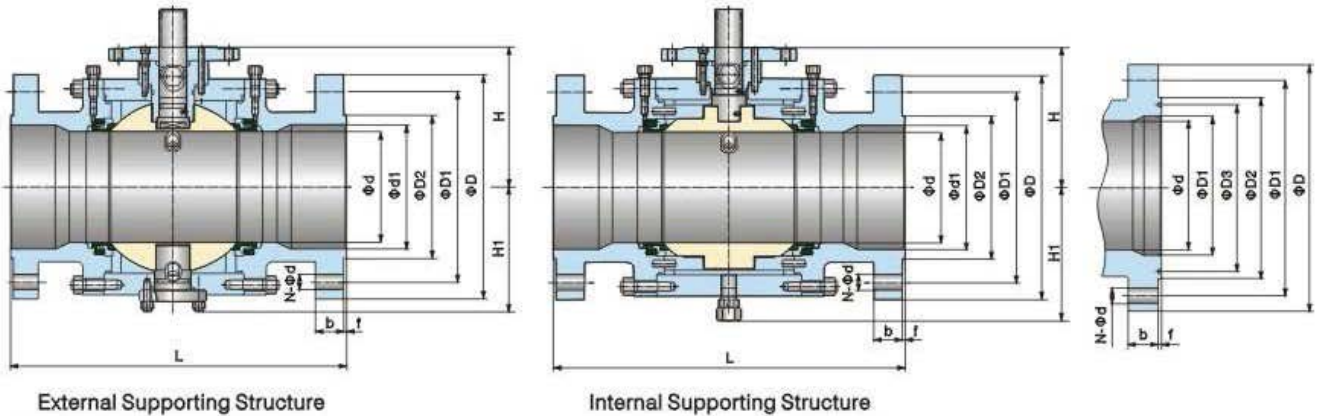

◆ Reduce Port

Pressure Rating	Nominal Diameter		d	d1	Flange	Butt Welding	Raised Face Flange						General		Support Board		Weight (kg)		
	Class	NPS					DN	L(RF)	L(BW)	D	D1	D2	D3	f	b	N-φd	H	H1	H
150	3"x2"	80	50	75	203	283	190	152.5	127	/	2	17.5	4-φ19	93	88	/	/	28	/
	4"x3"	100	75	100	229	305	230	190.5	157	/	2	22.3	8-φ19	118.5	117	/	/	45	/
	6"x4"	150	100	150	394	457	280	241.5	216	/	2	24	8-φ22	143	137	/	/	95	/
	8"x6"	200	150	201	457	521	345	298.5	270	/	2	27	8-φ22	208	178.5	/	/	170	179
	10"x8"	250	201	252	534	559	405	362	324	/	2	29	12-φ25	248	222	248	235	313	329
	12"x10"	300	252	303	610	635	485	432	381	/	2	30.5	12-φ25	294	265	294	288	470	494
	14"x10"	350	252	334	686	762	535	476	413	/	2	33.5	12-φ29	294	265	294	288	21	580
	14"x12"	350	303	334	686	762	535	476	413	/	2	33.5	12-φ29	344.5	308.5	345	330	760	940
	16"x12"	400	303	385	762	838	595	540	470	/	2	35	16-φ29	344.5	308.5	345	330	834	920
	16"x14"	400	334	385	762	838	595	540	470	/	2	35	16-φ29	377	334	377	360	930	1020
	18"x16"	450	385	436	864	914	635	578	533	/	2	38.5	16-φ32	418	375	418	400	1120	1210
	20"x16"	500	385	487	914	991	700	635	584	/	2	41.5	20-φ32	418	375	418	400	1480	1570
	20"x18"	500	436	487	914	991	700	635	584	/	2	41.5	20-φ32	463	410	463	431	1620	1710
	24"x20"	600	487	589	1067	1143	815	749.5	692	/	2	46.5	20-φ35	502	458	502	484	2270	1384
30"x24"	750	589	735	1295	1397	984	914.5	857	/	2	75	28-φ35	586	534	586	568	3730	3917	
36"x30"	900	735	874	1524	1727	1168	1086	1022	/	2	90	32-φ41	720	672	720	677	6730	7077	
300	3"x2"	80	50	75	283	283	210	168.5	127	/	2	27	8-φ22	93	88	/	/	42	/
	4"x3"	100	75	100	305	305	255	200	157	/	2	30.5	8-φ22	118.5	117	/	/	62	/
	6"x4"	150	100	150	403	457	320	270	216	/	2	35	12-φ22	143.5	137	/	/	115	120.8
	8"x6"	200	150	201	502	521	380	330	270	/	2	40	12-φ25	208	178.5	/	/	196	206
	10"x8"	250	201	252	568	559	445	387.5	324	/	2	46.5	16-φ29	248	222	248	235	350	368
	12"x10"	300	252	303	648	635	520	451	381	/	2	49.5	16-φ32	294	265	294	288	552	580
	14"x10"	350	252	334	762	762	585	514.5	413	/	2	52.5	20-φ32	294	265	294	288	644	684
	14"x12"	350	303	334	762	762	585	514.5	413	/	2	52.5	20-φ32	344.5	308.5	345	330	780	860
	16"x12"	400	303	385	838	838	650	571.5	470	/	2	56	20-φ35	344.5	308.5	345	330	908	988
	16"x14"	400	334	385	838	838	650	571.5	470	/	2	56	20-φ35	377	334	377	360	1105	1180
	18"x16"	450	385	436	914	914	710	628.5	533	/	2	59	24-φ35	423	380	423	345	1500	1575
	20"x16"	500	385	487	991	991	775	686	584	/	2	62	24-φ35	423	380	423	345	1600	1700
	20"x18"	500	436	487	991	991	775	686	584	/	2	62	24-φ35	463	410	463	431	1910	2053
	24"x20"	600	487	589	1143	1143	915	813	692	/	2	68.5	24-φ41	502	458	502	474	2940	3087
30"x24"	750	589	735	1397	1397	1092	997	857	/	2	96	28-φ48	592	549	592	561	4430	4652	
36"x30"	900	735	874	1727	1727	1270	1168	1022	/	2	112	32-φ54	730	682	730	681	7520	7896	

Note: The weight value is only for flanged valve. Please consult our factory for higher nominal diameter or weight. Any modification to size H, H1, and weight will not be notified otherwise.

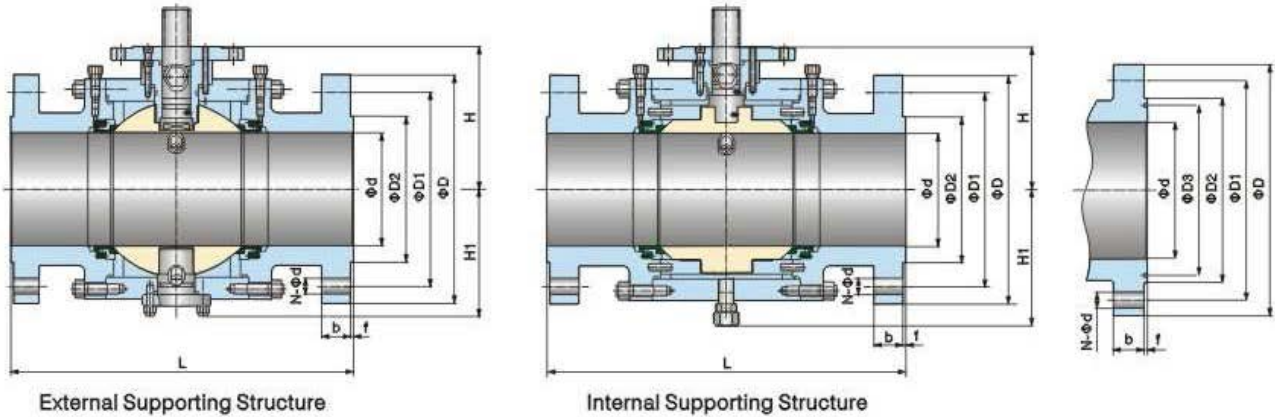

◆ Full Port

Pressure Rating	Nominal Diameter		d	Flange	Butt Welding	Raised Face Flange						General		Support Board		Weight (kg)		
	Class	NPS				DN	L(RF)	L(BW)	D	D1	D2	D3	f	b	N-φd	H	H1	H
600	2"	50	50	292	292	165	127	92	/	7	26	8-φ19	107	91.5	/	/	38	/
	3"	80	75	356	356	210	168.5	127	/	7	32	8-φ22	140	119	/	/	65	/
	4"	100	100	432	432	275	216	157	/	7	38.5	8-φ25	164	150	/	/	118	/
	6"	150	150	559	559	355	292	216	/	7	48	12-φ29	222	192.5	224	208	250	263
	8"	200	201	660	660	420	349	270	/	7	56	12-φ32	271	235	272	248	430	452
	10"	250	252	787	787	510	432	324	/	7	64	16-φ35	317.5	280	318	303	680	714
	12"	300	303	838	838	560	489	381	/	7	67	20-φ35	360	320	355	341	985	1034
	14"	350	334	889	889	605	527	413	/	7	70	20-φ39	390	350	390	370	1287	1351
	16"	400	385	991	991	685	603	470	/	7	77	20-φ41	440	395	400	415	1640	1722
	18"	450	436	1092	1092	745	654	533	/	7	83	20-φ44	485	439	485	460	2268	2381
	20"	500	487	1194	1194	815	724	584	/	7	89	24-φ44	533	490	533	510	2830	2972
	24"	600	589	1397	1397	940	838	692	/	7	102	24-φ51	616	573	616	595	4400	4620
	26"	650	633	1448	1448	1016	914.5	749	/	7	126	28-φ51	643.5	612	643.5	635	5455	5728
	28"	700	684	1549	1549	1073	965	800	/	7	132	28-φ54	665	670	665	692	7610	7991
30"	750	735	1651	1651	1130	1022	857	/	7	140	28-φ54	753	710	753	690	8420	8841	
32"	800	779	1778	1778	1194	1079.5	914	/	7	148	28-φ61	768	780	768	804	9230	9692	
36"	900	874	2083	2083	1314	1194	1022	/	7	162	28-φ67	861	840	861	865	13000	13650	
900	2"	50	50	368	368	215	165	124	95.25	7	38.5	8-φ25	126.5	105	/	/	57	/
	3"	80	75	381	381	240	190.5	156	123.83	7	38.5	8-φ25	150	130	/	/	87	/
	4"	100	100	457	457	290	235	181	149.23	7	45	8-φ32	172.5	158	/	/	193	/
	6"	150	150	610	610	380	317.5	241	211.12	7	56	12-φ32	230	197	235	210	340	357
	8"	200	201	737	737	470	393.5	308	269.88	7	64	12-φ39	285	250	290	255	570	598.5
	10"	250	252	838	838	545	470	362	323.85	7	70	16-φ39	330	294	330	316	912	957.6
	12"	300	303	965	965	610	533.5	419	381	7	79.5	20-φ39	366	334	366	351	1325	1391
	14"	350	334	1029	1029	640	559	467	419.1	7	86	20-φ42	415	368	425	376	1620	1701
	16"	400	373	1130	1130	705	616	524	469.9	7	89	20-φ45	452	408	452	421	1990	2090
	18"	450	423	1219	1219	785	686	594	533.4	7	102	20-φ51	501	461	501	463	2611	2742
	20"	500	471	1321	1321	855	749.5	648	584.2	7	108	20-φ54	544	506	544	505	3880	4074
	24"	600	570	1549	1549	1040	901.5	772	692.2	7	140	20-φ67	657	616	657	608	6296	6611
	26"	650	617	1651	1651	1086	952.5	749	/	7	160	20-φ73	700	635	700	625	7280	8050
	28"	700	665	1753	1753	1168	1022	800	/	7	172	20-φ79	727	685	727	673	9166	9624
30"	750	712	1880	1880	1232	1086	857	/	7	183	20-φ79	760	722	760	706	11277	11841	
32"	800	760	2032	2032	1314	1156	914	/	7	194	20-φ86	795	755	795	734	12300	12915	
36"	900	855	2286	2286	1461	1289	1022	/	7	215	20-φ92	886	846	886	822	17500	18375	

Note: The weight value is only for flanged valve. Please consult our factory for higher nominal diameter or weight. Any modification to size H, H1, and weight will not be notified otherwise.

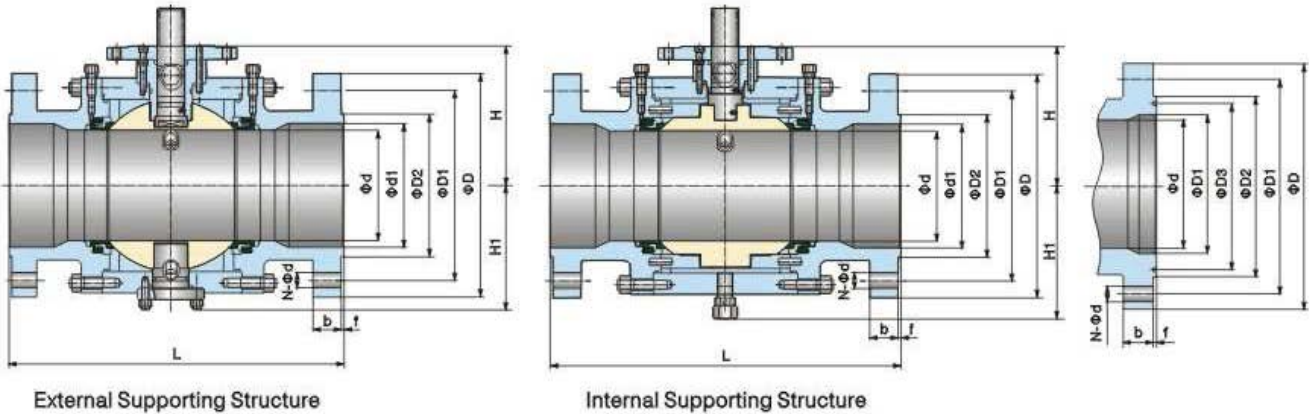

◆ Reduce Port

Pressure Rating	Nominal Diameter		d	d1	Flange L(RF)	Butt Welding L(BW)	Raised Face Flange						General		Support Board		Weight (kg)		
	Class	NPS					DN	D	D1	D2	D3	f	b	N-φd	H	H1	H	H1	General
600	3"x2"	80	50	75	356	356	210	168.5	127	/	7	32	8-φ22	107	91.5	/	/	44	/
	4"x3"	100	75	100	432	432	275	216	157	/	7	38.5	8-φ25	140	119	/	/	85	/
	6"x4"	150	100	150	559	559	355	292	216	/	7	48	12-φ29	167	150	/	/	169	177
	8"x6"	200	150	201	660	660	420	349	270	/	7	56	12-φ32	222	192.5	224	208	280	294
	10"x8"	250	201	252	787	787	510	432	324	/	7	64	16-φ35	271	235	272	248	520	546
	12"x10"	300	252	303	838	838	560	489	381	/	7	67	20-φ35	317.5	280	318	303	790	830
	14"x10"	350	252	334	889	889	605	527	413	/	7	70	20-φ39	317.5	280	318	303	960	1050
	14"x12"	350	303	334	889	889	605	527	413	/	7	70	20-φ39	360	320	355	341	1070	1180
	16"x12"	400	303	385	991	991	685	603	470	/	7	77	20-φ41	360	320	355	341	1250	1370
	16"x14"	400	334	385	991	991	685	603	470	/	7	77	20-φ41	390	350	390	370	1367	1490
	18"x16"	450	385	436	1092	1092	745	654	533	/	7	83	20-φ44	440	395	400	415	1840	1932
	20"x16"	500	385	487	1194	1194	815	724	584	/	7	89	24-φ44	440	395	400	415	2177	2340
	20"x18"	500	436	487	1194	1194	815	724	584	/	7	89	24-φ44	485	439	485	460	2390	2540
	24"x20"	600	487	589	1397	1397	940	838	692	/	7	102	24-φ51	533	490	533	510	3560	3738
	30"x24"	750	589	735	1651	1651	1130	1022	857	/	7	140	28-φ54	616	573	616	595	5200	5460
36"x30"	900	735	874	2083	2083	1314	1194	1022	/	7	162	28-φ67	753	710	753	690	9900	10395	
900	3"x2"	80	50	75	381	381	240	190.5	156	123.83	7	38.5	8-φ25	126.5	105	/	/	56	/
	4"x3"	100	75	100	457	457	290	235	181	149.23	7	45	8-φ32	150	130	/	/	97	/
	6"x4"	150	100	150	610	610	380	317.5	241	211.12	7	56	12-φ32	172.5	158	/	/	220	231
	8"x6"	200	150	201	737	737	470	393.5	308	269.88	7	64	12-φ39	230	197	235	210	436	458
	10"x8"	250	201	252	838	838	545	470	362	323.85	7	70	16-φ39	285	250	290	255	650	683
	12"x10"	300	252	303	965	965	610	533.5	419	381	7	79.5	20-φ39	330	294	330	316	1050	1103
	14"x10"	350	252	322	1029	1029	640	559	467	419.1	7	86	20-φ42	330	294	330	316	1230	1390
	14"x12"	350	303	322	1029	1029	640	559	467	419.1	7	86	20-φ42	366	334	366	351	1435	1565
	16"x12"	400	303	373	1130	1130	705	616	524	469.9	7	89	20-φ45	366	334	366	351	1700	1820
	16"x14"	400	322	373	1130	1130	705	616	524	469.9	7	89	20-φ45	415	368	415	376	1820	2080
	18"x16"	450	373	423	1219	1219	785	686	594	533.4	7	102	20-φ51	452	408	452	421	2550	2678
	20"x16"	500	373	471	1321	1321	855	749.5	648	584.2	7	108	20-φ54	452	408	452	421	2630	2765
	20"x18"	500	423	471	1321	1321	855	749.5	648	584.2	7	108	20-φ54	501	461	501	463	3630	3900
	24"x20"	600	471	570	1549	1549	1040	901.5	772	692.2	7	140	20-φ67	544	506	544	505	5030	5285
	30"x24"	750	570	712	1880	1880	1232	1086	857	/	7	183	20-φ79	657	616	657	608	8730	9167
36"x30"	900	712	855	2286	2286	1461	1289	1022	/	7	215	20-φ92	760	722	760	706	15385	16154	

Note: The weight value is only for flanged valve. Please consult our factory for higher nominal diameter or weight. Any modification to size H, H1, and weight will not be notified otherwise.

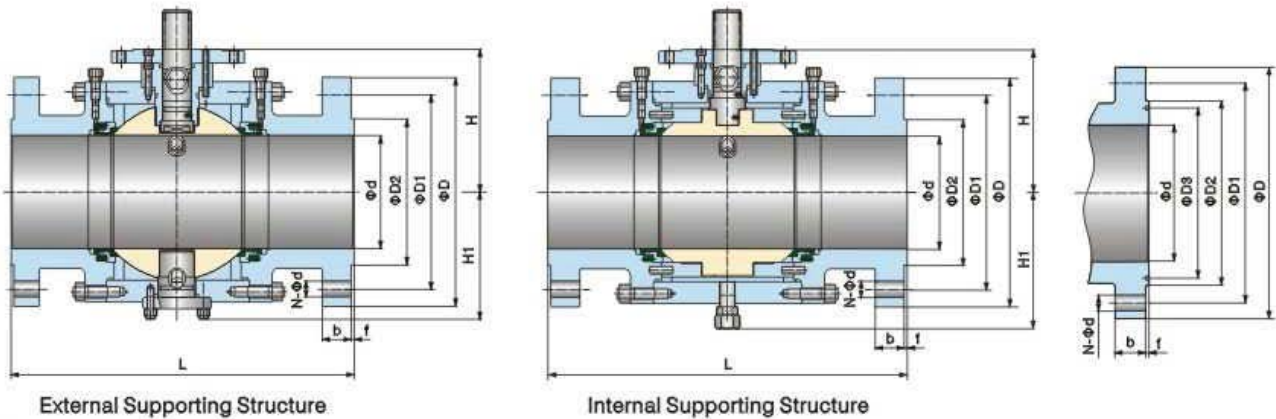

◆ Full Port

Pressure Rating	Nominal Diameter		d	Flange	Butt Welding	Raised Face Flange						General		Support Board		Weight (kg)		
	Class	NPS				DN	L(RF)	L(BW)	D	D1	D2	D3	f	b	N-φd	H	H1	H
1500	2"	50	50	368	368	215	165	124	95.25	7	38.5	8-φ25	126.5	105	/	/	57	/
	3"	80	75	470	470	265	203.2	168	136.53	7	48	8-φ32	166	149	/	/	168	/
	4"	100	100	546	546	310	241.3	194	161.93	7	54	8-φ35	219	178	/	/	230	/
	6"	150	144	705	705	395	317.5	248	211.14	7	83	12-φ39	268	227	/	/	685	/
	8"	200	192	832	832	485	393.7	318	269.88	7	92	12-φ45	303	267	305	270	993	1043
	10"	250	239	991	991	585	482.6	371	323.85	7	108	12-φ51	358	323	358	336	1781	1870
	12"	300	287	1130	1130	675	571.5	438	381	7	124	16-φ54	414	381	414	395	2280	2394
	14"	350	315	1257	1257	750	635	489	419.1	7	134	16-φ60	471	432	471	441	3000	3150
	16"	400	360	1384	1384	825	704.8	546	469.9	7	146.5	16-φ67	498	453	498	456	3816	4007
	18"	450	406	1537	/	915	774.7	613	533.4	7	162	16-φ73	570	530	570	535	6195	6505
20"	500	454	1664	/	985	831.8	673	584.2	7	178	16-φ79	611	569	611	561	9075	9529	
2500	2"	50	42	451	451	235	171.4	133	101.6	7	51	8-φ29	149	123	/	/	140	/
	3"	80	62	578	578	305	228.6	168	127	7	67	8-φ35	215	171	/	/	216	/
	4"	100	87	673	673	355	273	203	157.18	7	76.5	8-φ42	245	206	/	/	328	/
	6"	150	131	914	914	485	368.3	279	228.6	7	108	8-φ54	306	263	306	265	1030	1082
	8"	200	179	1022	1022	550	438.2	340	279.4	7	127	12-φ54	361	330	361	336	1570	1649
	10"	250	223	1270	1270	675	539.8	425	342.9	7	166	12-φ67	426	388	426	394	2550	2578
	12"	300	265	1422	1422	760	619.1	495	406.4	7	185	12-φ74	479	440	479	446	3872	4066

Note: The weight value is only for flanged valve. Please consult our factory for higher nominal diameter or weight. Any modification to size H, H1, and weight will not be notified otherwise.

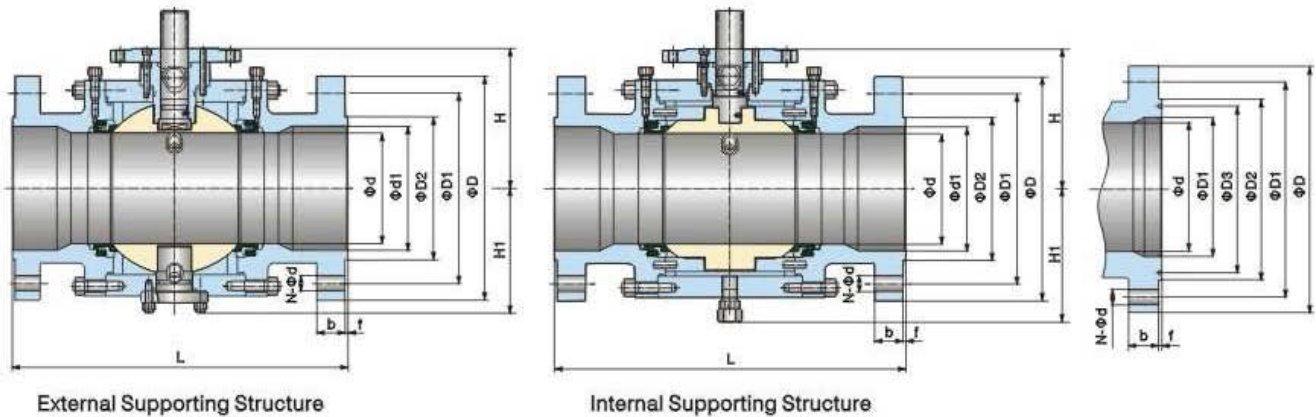

◆ Reduce Port

Pressure Rating	Nominal Diameter		d	d1	Flange	Butt Welding	Raised Face Flange						General		Support Board		Weight (kg)		
	Class	NPS					DN	L(RF)	L(BW)	D	D1	D2	D3	f	b	N-Φd	H	H1	H
1500	3"x2"	80	50	75	470	470	265	203.2	168	136.53	7	48	8-Φ32	126.5	105	/	/	2	/
	4"x3"	100	75	100	546	546	310	241.3	194	161.93	7	54	8-Φ35	166	149	/	/	195	205
	6"x4"	150	100	144	705	705	395	317.5	248	211.14	7	83	12-Φ39	219	178	/	/	270	284
	8"x6"	200	144	192	832	832	485	393.7	318	269.88	7	92	12-Φ45	268	227	/	/	586	615
	10"x8"	250	192	239	991	991	585	482.6	371	323.85	7	108	12-Φ51	303	267	305	270	1010	1061
	12"x10"	300	239	287	1130	1130	675	571.5	438	381	7	124	16-Φ54	358	323	358	336	1760	1848
	14"x10"	350	239	315	1257	1257	750	635	489	419.1	7	134	16-Φ60	358	323	358	336	2010	2238
	14"x12"	350	287	315	1257	1257	750	635	489	419.1	7	134	16-Φ60	414	381	414	395	2680	2840
	16"x12"	400	287	360	1384	1384	825	704.8	546	469.9	7	146.5	16-Φ67	414	381	414	395	2860	3180
	16"x14"	400	315	360	1384	1384	825	704.8	546	469.9	7	146.5	16-Φ67	471	432	471	441	3530	3850
	18"x16"	450	360	406	1537	/	915	774.7	613	533.4	7	162	16-Φ73	498	453	498	456	5030	5282
20"x16"	500	360	454	1664	/	985	831.8	673	584.2	7	178	16-Φ79	498	453	498	355	/	/	
20"x18"	500	406	454	1664	/	985	831.8	673	584.2	7	178	16-Φ79	570	530	570	456	5380	5790	
2500	3"x2"	80	42	62	578	578	305	228.6	168	127	7	67	8-Φ35	149	123	/	/	157	165
	4"x3"	100	62	87	673	673	355	273	203	157.18	7	76.5	8-Φ42	215	171	/	/	260	273
	6"x4"	150	87	131	914	914	485	368.3	279	228.6	7	108	8-Φ54	245	206	/	/	548	575
	8"x6"	200	131	179	1022	1022	550	438.2	340	279.4	7	127	12-Φ54	306	263	306	265	1100	1155
	10"x8"	250	179	223	1270	1270	675	539.8	425	342.9	7	166	12-Φ67	361	330	361	336	1890	1985
	12"x10"	300	223	265	1422	1422	760	619.1	495	406.4	7	185	12-Φ74	426	388	426	394	2850	2993

Note: The weight value is only for flanged valve. Please consult our factory for higher nominal diameter or weight. Any modification to size H, H1, and weight will not be notified otherwise.

Cast Steel Trunnion Ball Valve

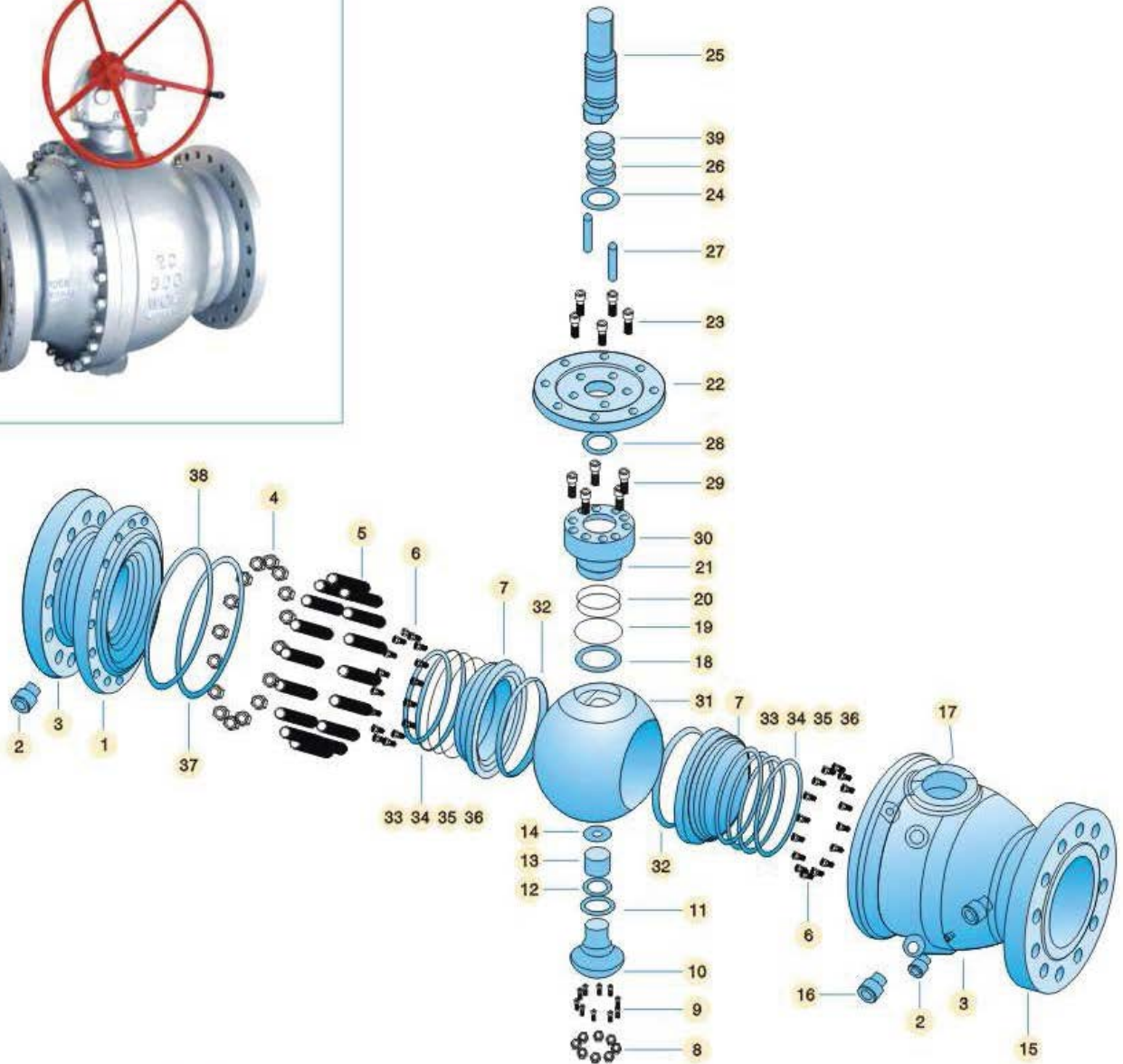

◆ Cast Steel Trunnion Ball Valve

1	2	3	4	5	6	7	8	9	10	11	12	13
End Adapter	Seat Injection Fitting	Damping Valve	Nut	Stud	Spring	Seat Retainer	Nut	Stud	Lower Cover	Gasket	O-ring	Thrust Bearing
14	15	16	17	18	19	20	21	22	23	24	25	26
Stem Bearing	Body	Vent Valve	Plug	Stem Bearing	O-ring	Sliding Bearing	Stem Injection Fitting	Gland	Socket Head Cap Screw	Stem Bearing	Stem	O-ring
27	28	29	30	31	32	33	34	35	36	37	38	39
Pin	Packing	Socket Head Cap Screw	Packing Box	Ball	Seat	O-ring	Gasket	Fire Proof Ring	O-ring	O-ring	Gasket	Gasket

◆ Part Materials and Main Parameters

Nominal diameter (in)		NPS1/2-8				
Nominal Pressure (MPa)		Class150~Class900				
No.	Part Name	Material				
		Carbon steel	Stainless steel			
1	End Adapter	ASTM A216 WCB	ASTM A351 CF8	ASTM A351 CF8M	ASTM A351 CF3	ASTM A351 CF3M
2	Seat Injection Fitting	CS+ZN	A182 F304	A182 316	A182 F304	A182 316
3	Damping Valve	CS+ZN	A182 F304	A182 316	A182 F304	A182 316
4	Nut	2HM	A194 8	A194 8M	A194 8	A194 8M
5	Stud	A193 B7M	A320 B8	A320 B8M	A320 B8	A320 B8M
6	Spring	INCONEL X750				
7	Seat Retainer	A105N+ENP	A182 F304	A182 F316	A182 F304L	A182 F316L
8	Nut	2HM	A194 B8	A194 8M	A194 8	A194 8M
9	Stud	A193 B7M	A320 B8	A320 B8M	A320 B8	A320 B8M
10	Lower Cover	ASTM A105 · ENP	ASTM A182 304	ASTM A182 316	ASTM A182 304L	ASTM A182 316L
11	Gasket	316+graphite	316+graphite	316+graphite	316+graphite	316+graphite
12	O-ring	VITON				
13	Thrust Bearing	PTFE				
14	Stem Bearing	45+PTFE	316+PTFE	316+PTFE	316+PTFE	316+PTFE
15	Body	ASTM A216 WCB	ASTM A351 CF8	ASTM A351 CF8M	ASTM A351 CF3	ASTM A351 CF3M
16	Vent Valve	CS+ZN	A182 F304	A182 316	A182 F304	A182 316
17	Plug	CS+ZN	A182 F304	A182 316	A182 F304	A182 316
18	Stem Bearing	PTFE	PTFE	PTFE	PTFE	PTFE
19	O-ring	VITON				
20	Sliding Bearing	Metal+PTFE	Metal+PTFE	Metal+PTFE	Metal+PTFE	Metal+PTFE
21	Stem Injection Fitting	CS+ZN	A182 F304	A182 316	A182 F304	A182 316
22	Gland	A105N	A182 F304	A182 316	A182 F304L	A182 316L
23	Socket Head Cap Screw	A193 B7M	A320 B8	A320 B8M	A320 B8	A320 B8M
24	Stem Bearing	PTFE	PTFE	PTFE	PTFE	PTFE
25	Stem	ASTM A182 F6a	ASTM A182 304	ASTM A182 316	ASTM A182 304L	ASTM A182 316L
26	O-ring	VITON				
27	Pin	A182 316	A182 316	A182 316	A182 316	A182 316
28	Packing	Graphite				
29	Socket Head Cap Screw	A193 B7M	A320 B8	A320 B8M	A320 B8	A320 B8M
30	Packing Box	A105N	A182 F304	A182 316	A182 F304L	A182 316L
31	Ball	ASTM A105 · ENP	ASTM A182 304	ASTM A182 316	ASTM A182 304L	ASTM A182 316L
32	Seat	PTFE/NYLON/PEEK/PPL				
33	O-ring	VITON				
34	Gasket	Graphite	Graphite	Graphite	Graphite	Graphite
35	Fire Proof Ring	316+graphite	316+graphite	316+graphite	316+graphite	316+graphite
36	O-ring	VITON				
37	O-ring	VITON				
38	Gasket	Graphite	Graphite	Graphite	Graphite	Graphite
39	Gasket	316+graphite	316+graphite	316+graphite	316+graphite	316+graphite
Applicable Service Conditions	Applicable Media	Water, steam, oil, gas, liquefied gas, natural gas, etc.	Nitric acid	Acetic acid	Strong Oxidizer	Urea
	Applicable Temperature	120°C(PTFE)、≤80°C(NYLON)、≤250°C(PEEK)、≤250°C(PPL)				
Design And Manufacturing		API 608、API 6D				
Face-to-face Dimensions		ASME B16.10、API 6D				
Type Of Connection		Flange	ASME B16.5/ASME B16.47		Butt welding	ASME B16.25
Pressure Test		API 598、API6D				
Transmission Mode		Manual, worm and worm gear transmission, pneumatic, electric				

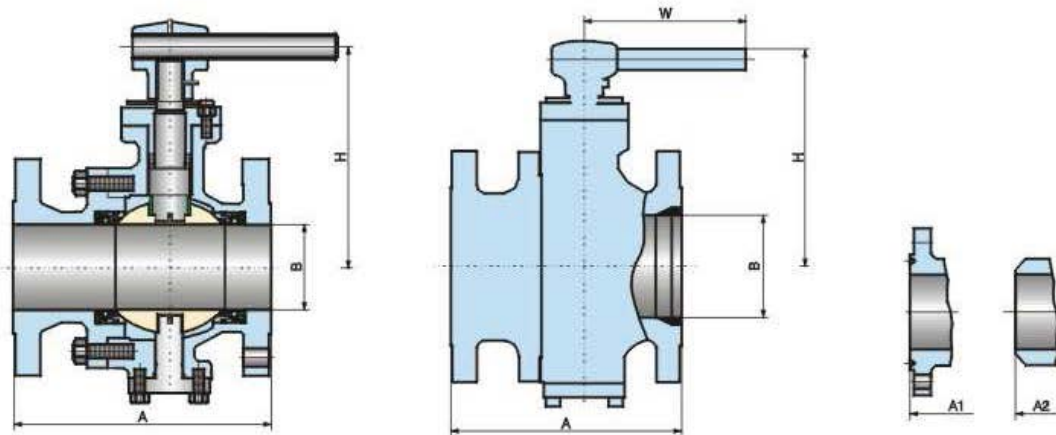

Class	NPS Inch	A	A1	A2	B	H	W	WT
		mm	mm	mm	mm	mm	mm	Kg
Class 150	2	178	191	216	49	152	300	19
	3x2	203	216	283	49	152	300	32
	3	203	216	283	74	176	450	36
	4x3	229	241	305	74	176	450	50
	4	229	241	305	100	205	650	53
	6x4	394	406	457	100	205	650	96
	*6	394	406	457	150	300	460	100
	6x8	457	470	521	150	300	460	150
	*8	457	470	521	201	150	600	172
	*10x8	533	546	559	201	360	600	275
	*10	533	546	559	252	374	600	284
	*12x10	610	622	635	252	374	600	482
	*12	610	622	635	303	415	600	494
*14x12	686	699	762	303	415	600	600	
Class 300	2	216	232	216	49	138	400	18
	3x2	283	298	283	49	138	400	25
	3	283	298	283	74	215	400	30
	4x3	305	321	305	74	215	400	62
	4	305	321	305	100	250	650	95
	6x4	403	419	457	100	250	650	154
	*6	403	419	457	150	310	460	200
	6x8	502	518	521	150	310	460	230
	*8	502	518	521	201	343	600	246
	*10x8	568	584	559	201	343	600	300
	*10	568	584	559	252	396	600	308
	*12x10	648	664	635	252	396	600	496
	*12	648	664	635	303	423	600	512
*14x12	762	778	762	303	423	600	650	
Class 600	2	292	295	292	49	157	400	30
	3x2	356	359	356	49	157	400	42
	3	356	359	356	74	181	600	55
	4x3	432	435	432	74	181	600	72
	4	432	435	432	100	222	650	86
	6x4	559	562	559	100	222	650	128
	*6	559	562	559	150	325	460	225
	6x8	502	518	521	150	310	460	230
	*8	660	664	660	201	355	600	354
	*10x8	787	791	787	201	355	600	447
	*10	787	791	787	252	400	600	604
	*12x10	838	841	838	252	400	600	740
	*12	838	841	838	303	440	600	830
*14x12	889	892	889	303	440	600	1070	
16x12	991	994	991	305	440	600	1658	

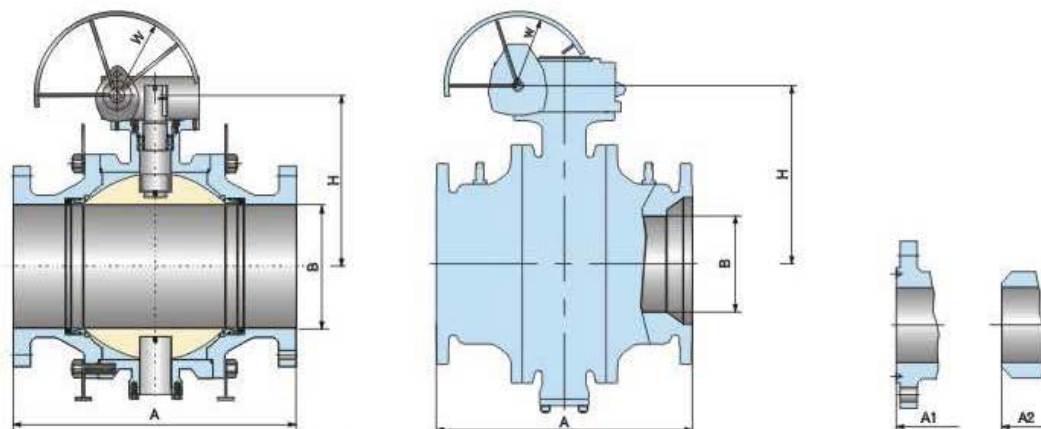

The 3 piece body be used for 14" and above.

CLASS 150							
NPS Inch	A mm	A1 mm	A2 mm	B mm	H mm	W mm	WT Kg
14	686	699	762	334	600	460	592
16x12	762	775	838	303	600	440	564
16x14	762	775	838	334	600	460	655
16	762	775	838	385	700	500	805
18x16	864	876	914	385	700	500	905
18	864	876	914	436	700	540	954
20x18	914	927	991	436	700	540	1141
20	914	927	991	487	700	570	1308
24x20	1067	1080	1143	487	700	570	1525
24	1067	1080	1143	589	700	660	1656
28x24	1245	/	1346	589	700	660	1989
28	1245	/	1346	684	762	810	2409
30x28	1295	/	1397	684	762	810	2520
32x28	1372	/	1524	684	762	810	2830
30	1295	/	1397	735	762	930	2686
32	1372	/	1524	779	762	965	3096
34	1473	/	1626	832	1110	965	7950
36	1524	/	1728	876	1170	965	8950
40	1753	/	1956	978	1290	965	12730
42	1855	/	2083	1022	1345	965	14450
48	2134	/	2388	1168	1510	965	21750
56	2849	/	2489	1384	1735	965	34300

CLASS 300							
NPS Inch	A mm	A1 mm	A2 mm	B mm	H mm	W mm	WT Kg
14	762	778	762	334	420	700	612
16x12	838	854	838	303	386	600	592
16x14	838	854	838	334	420	700	925
16	838	854	838	385	530	700	1018
18x16	914	930	914	385	530	700	1110
18	914	930	914	436	580	700	1181
20x18	991	1010	991	436	580	700	1280
20	991	1010	991	487	640	762	1352
24x20	1143	1165	1143	487	640	762	1710
24	1143	1165	1143	589	720	762	1906
28x24	1346	1372	1346	589	720	762	2008
28	1346	1372	1346	684	918	762	2114
30x28	1397	1422	1397	684	918	762	2312
32x28	1524	1553	1524	684	918	762	2419
30	1397	1422	1397	735	1100	762	2355
32	1524	1553	1524	779	1360	762	2586
34	1626	1654	1626	832	1108	965	9082
36	1727	1756	1727	876	1270	965	10280
40	1956	/	1956	978	1240	965	13970
42	2083	/	2083	1022	1290	965	16300
48	2170	/	2388	1168	1465	965	24300
56	2743	/	2743	1384	1710	965	38400

CLASS 600							
NPS Inch	A mm	A1 mm	A2 mm	B mm	H mm	W mm	WT Kg
14	889	892	889	334	700	450	1150
16x12	991	994	991	303	700	440	1016
16x14	991	994	991	334	700	450	1218
16	991	994	991	385	700	500	1550
18x16	1092	1095	1092	385	700	500	1640
18	1092	1095	1092	436	762	560	2145
20x18	1194	1200	1194	436	762	560	2296
20	1194	1200	1194	487	762	620	2864
24x20	1397	1407	1397	487	762	620	3018
24	1397	1407	1397	589	762	700	3696
28x24	1549	1562	1549	589	762	700	3998

CLASS 600							
NPS Inch	A mm	A1 mm	A2 mm	B mm	H mm	W mm	WT Kg
28	1549	1562	1549	684	762	840	4060
30x28	1651	1664	1651	684	762	840	4290
32x28	1778	1794	1778	684	762	840	4584
32	1778	1794	1778	781	1195	965	9940
34	1930	1946	1930	832	1245	965	11570
36	2083	2098	2083	876	1315	965	13530
40	2337	2337	2337	978	1320	965	18570
42	2437	2437	2437	1022	1405	965	21590
48	2540	2540	2540	1168	1595	965	31550
56	2949	2949	2949	1384	1855	965	47840

FLOATING BALL VALVE SERIES



Floating Ball Valve

◆ Structural Features

1. Special Seat Design

The floating ball valve adopts the design of flexible seal ring structure. When the medium pressure is lower, the contact area of seal ring and ball is smaller. So higher sealing ratio is formed at the place where the seal ring and ball contact to ensure reliable sealing. When the medium pressure is higher, the contact area of seal ring and ball becomes bigger along with the elastic deformation of seal ring, so the seal ring can endure higher medium thrust without being damaged.

Elastic seat

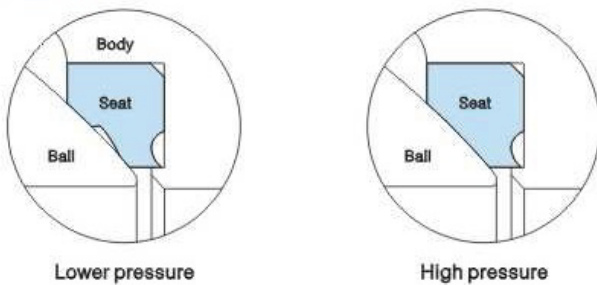

Fire Safe Structure Design of Stem

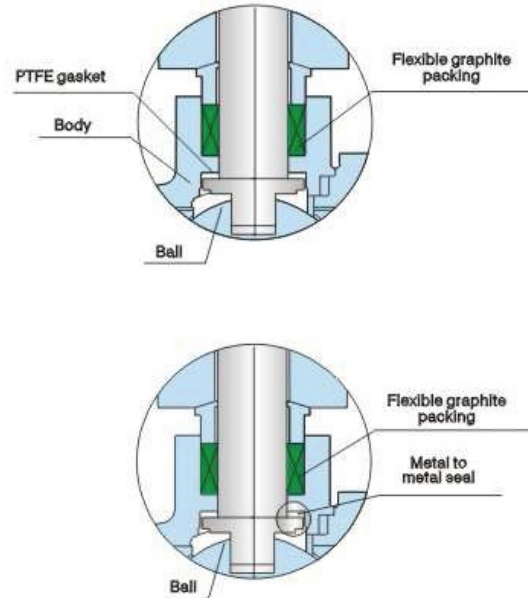

2. Fire Safe Structure Design

In case of fire during the use of the valve the soft components such as the seat ring inserts, stem o-rings, body o-rings etc. which may be made of PTFE, rubber and other elastomers can become damaged due to the high temperatures. In this instance the metal seat rings which have a specially designed geometry with move towards the ball and effectively make a metal to metal seal to control leakage that would otherwise occur. The fire safe design of trunnion pipeline ball valves conforms to the requirements of API 607, API 6FA, BS 6755 and other industry standards.

Fire Safe Structure of Seat

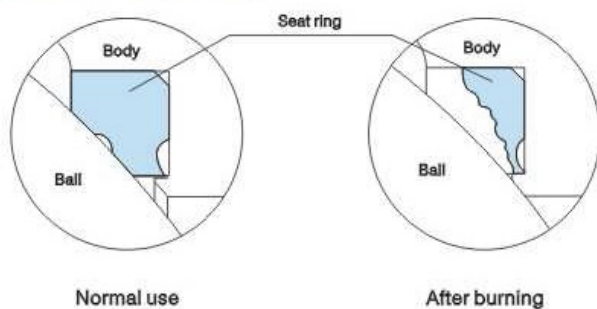

3. Anti-static Design

The antistatic design ensures that no differential electrical potential can build up across or within the valve when operating in any position or being opened and closed, thus avoiding the potential of a static discharge spark that could cause a fire. To achieve this, the ball and stem, seat rings and body parts must be electrically continuous. This is achieved by ensuring that wherever soft components such as o-rings, gaskets and seat inserts are used they cannot totally insulate or isolate the metal parts from one another; electrical continuity is achieved via other metallic components staying in contact.

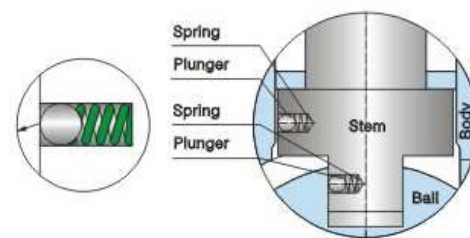

Anti-static structure design of ball valve with DN ≥ 32

Fire Safe Structure of Middle Flange

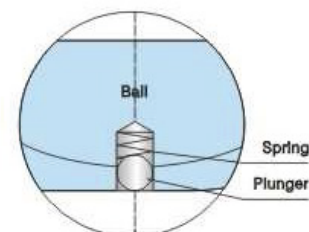
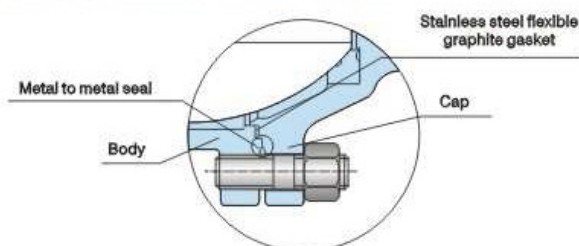

Anti-static structure design of ball valve with DN ≤ 25

◆ **Structural Features**

4. Reliable Sealing of Valve Stem

The stem is provided with the shoulder at its bottom so that it will not be blown out by the medium even under the extreme conditions such as abnormal pressure rise inside the valve cavity, failure of gland plate and etc. In addition, to avoid leakage after the stem packing is burnt in case of fire, the thrust bearing is set at the place where the stem shoulder and

body contact to form a reverse sealing seat. The sealing force of the reverse seal will increase according to the increase of medium pressure, so as to ensure reliable stem sealing under various pressure, prevent leakage and avoid accident spreading.

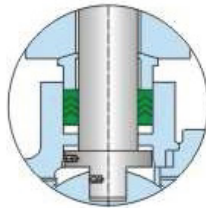

The bottom-mounted stem will not be blown out by medium pressure.

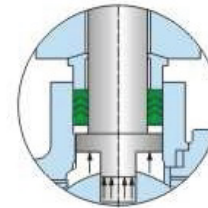

The top-mounter stem may be blown out by medium pressure

The stem adopts V type packing sealing structure, the V type packing can effectively change the pressing force and medium force of the gland into the sealing force of the stem. According to user requirements, the

disc spring loaded packing pressing mechanism can be adopted to make the sealing of stem packing more reliable.

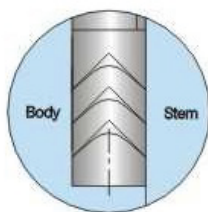

Before the packing is pressed

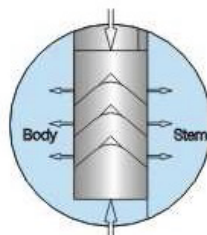

After the packing is pressed

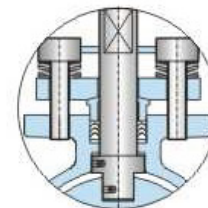

The disc spring loaded packing pressing mechanism is adopted.

5. Lock and Misoperation Prevention

The manual ball valve can be locked by a lock when it is at the full open or full close position. The 90° open and close positioning piece with lock hole is designed to avoid valve misoperation caused due to handle operation by non-operators, and it can also prevent valve opening or closing, or other accidents caused by pipeline vibration or unpredictable factors. It is very

effective especially for inflammable and explosive oil, chemical and medical working pipelines or field tubing. The part on the head of the stem that is installed with the handle adopts flat design. Where the valve is opened, the handle is parallel to the pipeline, and closing indications of the valve are guaranteed to have no error.

Lock and Misoperation Prevention Structure

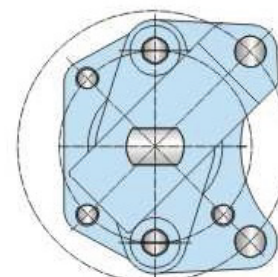
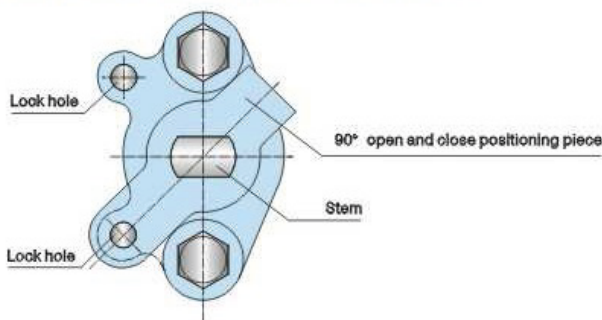

2PCS Body Floating Ball Valve



◆ **Forge Steel 2PCS Body Floating Ball Valve**

1	2	3	4	5	6	7	8	9	10	11
Body	Tailpiece	Stem	Ball	Stem Thrust Washer	Stem Bearing	Stem Packing	Gland	Washer Spring	Stem Nut	Stop Plate
12	13	14	15	16	17	18	19	20	21	
Locking Plate	Stop Pins	Seat Ring	Body Fire Safe Seal	Anti-Static Device	Lever Screw	Retainer Ring	Lever	Body Studs	Body Nuts	

◆ Part Materials And Main Parameters

Item	Part	Standard (Nace)	Low Temp (Nace)	Stainless Steel (Nace)
1	Body	A105	A350 LF2	A182 Gr.316
2	Tailpiece	A105	A350 LF2	A182 Gr.316
3	Stem	A182 Gr.316	A182 Gr.316	A182 Gr.316
4	Ball	A182 Gr.316	A182 Gr.316	A182 Gr.316
5	Stem Thrust Washer	RPTFE	RPTFE	RPTFE
6	Stem Bearing	RPTFE	RPTFE	RPTFE
7	Stem Packing	Graphite	Graphite	Graphite
8	Gland	ASTM A276 GR. 410	ASTM A276 GR.410	ASTM A276 GR.316
9	Washer Spring	Harmonic Steel	Harmonic Steel	17-7PH
10	Stem Nut	A194 Gr.2HM	A194 Gr.7M	A194 Gr.8M
11	Stop Plate	Carbon Steel+Zn	Carbon Steel+Zn	Stainless Steel
12	Locking Plate	Carbon Steel+Zn	Carbon Steel+Zn	Stainless Steel
13	Stop Pins	Stainless Steel	Stainless Steel	Stainless Steel
14	Seat Ring	RPTFE	RPTFE	RPTFE
15	Body Fire Safe Seal	Spiral Wound Gasket	Spiral Wound Gasket	Spiral Wound Gasket
16	Anti-Static Device	316 S.S.	316 S.S.	316 S.S.
17	Lever Screw	Carbon Steel+Painting	Carbon Steel+Painting	Carbon Steel+Painting
18	Retainer Ring	AISI 1566	AISI 1566	AISI 1566
19	Lever	Carbon Steel+Painting	Carbon Steel+Painting	Carbon Steel+Painting
20	Body Studs	A193 Gr.B7M	A193 Gr.L7M	A193 Gr.B8M
21	Body Nuts	A194 Gr.2HM	A194 Gr.7M	A194 Gr.8M

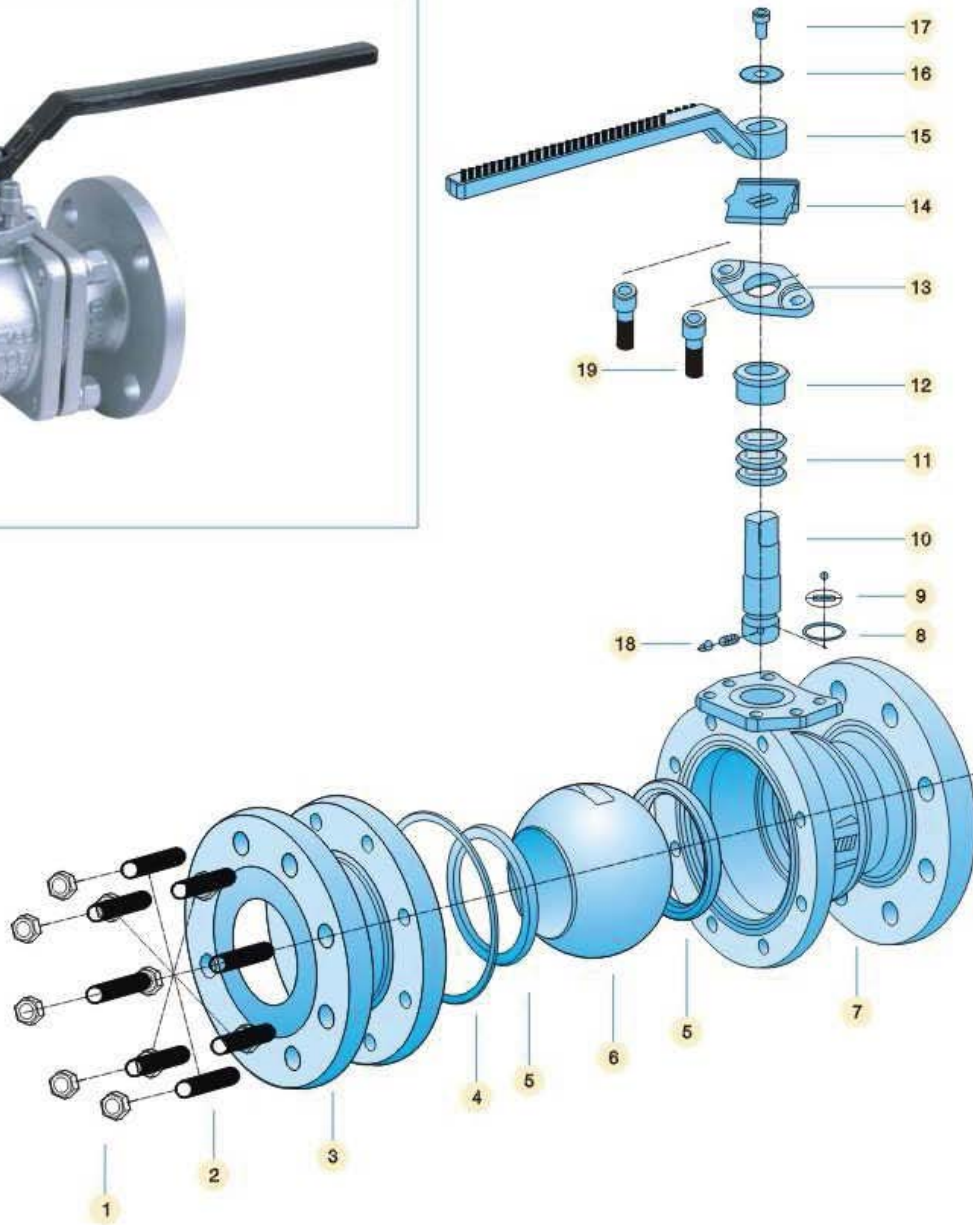

◆ Cast Steel 2PCS Body Floating Ball Valve

1	2	3	4	5	6	7	8	9	10
Nut	Stud	End Adapter	Gasket	Seat	Ball	Body	Stem Bearing	O-Ring	Stem
11	12	13	14	15	16	17	18	19	
Packing	Packing Bushing	Packing Gland	Stopper	Handle	Metal Pad	Screw	Anti-static Device	Socket Head Cap Screw	

◆ Part Materials And Main Parameters

Nominal Diameter (in)		NPS 1/2~8				
Nominal Pressure (MPa)		Class150~Class600				
No.	Part Name	Material				
		Carbon steel	Stainless steel			
1	Body	ASTM A216 WCB	ASTM A351 CF8	ASTM A351 CF8M	ASTM A351 CF8	ASTM A351 CF3M
2	Stud	A197 B7M	A320 B8	A320 B8M	A320 B8	A320 B8M
3	Seat	PTFE/NYLON/PEEK/PPL				
4	Ball	ASTM A105 • ENP	ASTM A182 304	ASTM A182 316	ASTM A182 304L	ASTM A182 316L
5	Anti-fire Gasket	SST+Graphite				
6	End Adapter	ASTM A216 WCB	ASTM A351 CF8	ASTM A351 CF8M	ASTM A351 CF8	ASTM A351 CF3M
7	Hexagon Nut	A194 2HM	A194-8	A194-8M	A194-8	A194-8M
8	Anti-static Device	Combined parts	Combined parts	Combined parts	Combined parts	Combined parts
9	Stem	ASTM A182 F6A	ASTM A182 304	ASTM A182 316	ASTM A182 304L	ASTM A 182 316L
10	Thrust Bearing	PTFE				
11	Sliding Bearing	PTFE				
12	Packing	Graphite				
13	Packing Bushing	ASTM A182 F6A	ASTM A182 F6A	ASTM A182 F6A	ASTM A182 F6A	ASTM A182 F6A
14	Packing Gland	ASTM A216 WCB	ASTM A216 WCB	ASTM A216 WCB	ASTM A216 WCB	ASTM A216 WCB
15	Socket Head Cap Screw	A197 B7M	A197 B7M	A197 B7M	A197 B7M	A197 B7M
16	Stopper	A3.Zn	A3.Zn	A3.Zn	A3.Zn	A3.Zn
17	Retainer Ring	65Mn	65Mn	65Mn	65Mn	65Mn
Applicable Service Conditions	Applicable Media	Water, steam, oil, gas, liquefied gas, natural gas, etc.	Nitric acid	Acetic acid	Strong oxidizer	Urea
	Applicable Temperature	≤120°C (PTFE) 、 ≤80°C (NYLON) 、 ≤250°C (PEEK) 、 ≤250°C (PPL)				
Design And Manufacturing		API 608				
Face-to-face Dimensions		ASME B16.10				
Type Of Connection		Flange	ASME B16.5		Butt welding	ASME B16.25
Pressure Test		API 598				
Transmission Mode		Manual, worm and worm gear transmission, pneumatic, electric				

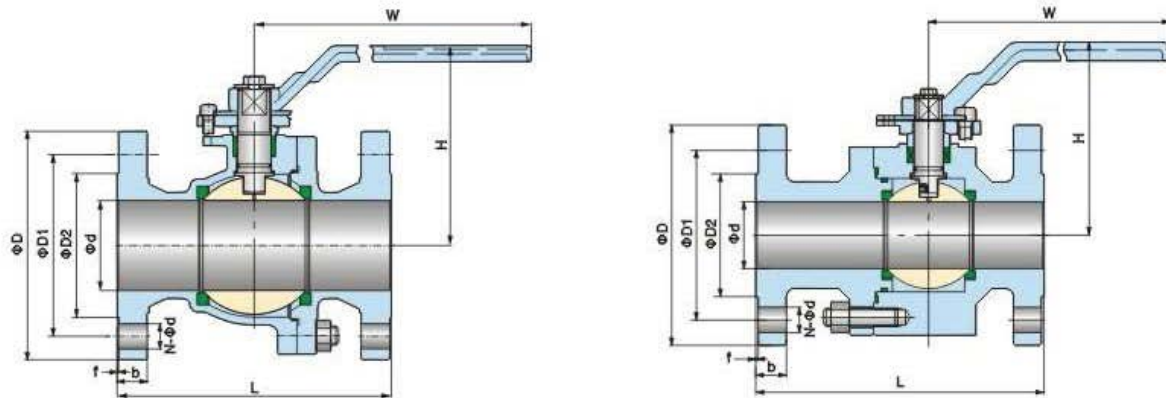

◆ Full Port

Pressure Rating	Nominal Diameter		d	Flanged L(RF)	Raised Face Flange						W	Cast Steel H	Weight (kg) Cast Steel	
	Class	NPS			DN	D	D1	D2	f	b				N-Ød
150		1/2"	15	13	108	90	60.5	35	2	9	4-Ø16	140	80	2
		3/4"	20	19	117	100	70	43	2	10	4-Ø16	140	86	2.5
		1"	25	25	127	110	79.5	51	2	11	4-Ø16	140	98	3.5
		1 1/4"	32	32	140	115	89	64	2	11	4-Ø16	180	106	6.5
		1 1/2"	40	38	165	125	98.5	73	2	13	4-Ø16	180	133	7.5
		2"	50	51	178	150	120.5	92	2	14.5	4-Ø19	200	138	9
		3"	80	76	203	190	152.5	127	2	17.5	4-Ø19	300	175	19
		4"	100	102	229	230	190.5	157	2	22.5	8-Ø19	650	235	36
		6"	150	152	394	280	241.5	216	2	24	8-Ø22	800	285	78
	8"	200	203	457	345	298.5	270	2	27	8-Ø22	1000	342	160	
300		1/2"	15	13	140	95	66.5	35	2	13	4-Ø16	140	80	2.5
		3/4"	20	19	152	115	82.5	43	2	14.5	4-Ø19	140	86	3.6
		1"	25	25	165	125	89	51	2	16	4-Ø19	140	98	5
		1 1/4"	32	32	178	135	98.5	64	2	17.5	4-Ø19	180	106	8.5
		1 1/2"	40	38	191	155	114.5	73	2	19.5	4-Ø22	180	133	10
		2"	50	51	216	165	127	92	2	21	8-Ø19	200	138	12
		3"	80	73	283	210	168.5	127	2	27	8-Ø22	300	175	28
		4"	100	102	305	255	200	157	2	30.5	8-Ø22	650	235	46
		6"	150	152	403	320	270	216	2	35	12-Ø22	800	285	104
	8"	200	203	502	380	330	270	2	40	12-Ø25	1000	342	208	

Please consult the factory:

Note: The weight value in only for flanged valve. Please consult our factory for higher nominal diameter or weight. Any modification to sizes H, H1 and weight will not be notified otherwise.

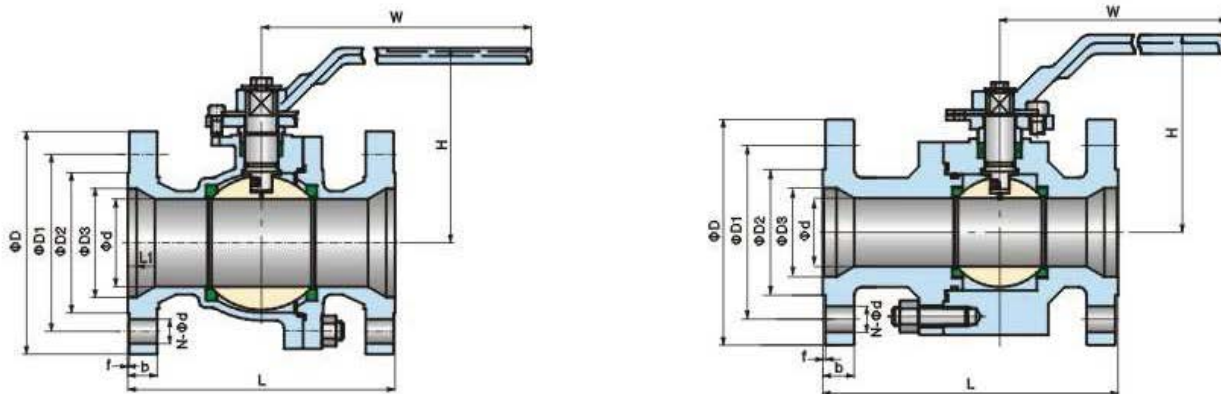

◆ Reduce Port

Pressure Rating	Nominal Diameter		d	d1	Flanged	Raised Face Flange						W	Cast Steel	Weight (kg)
						L(RF)	D	D1	D2	f	b			
150	3/4"x1/2"	20	13	19	117	100	70	43	2	10	4-Ø16	140	80	Δ
	1"x3/4"	25	19	25	127	110	79.5	51	2	11	4-Ø16	140	86	Δ
	1 1/4"x1"	32	25	32	140	115	89	64	2	11	4-Ø16	180	98	Δ
	1 1/2"x1 1/4"	40	32	38	165	125	98.5	73	2	13	4-Ø16	180	106	Δ
	2"x1 1/2"	50	38	51	178	150	120.5	92	2	14.5	4-Ø19	200	133	8
	3"x2"	80	51	76	203	190	152.5	127	2	17.5	4-Ø19	300	138	14
	4"x3"	100	76	102	229	230	190.5	157	2	22.5	8-Ø19	650	175	24
	6"x4"	150	102	152	267	280	241.5	216	2	24	8-Ø22	800	235	41
300	3/4"x1/2"	20	13	19	152	115	82.5	43	2	14.5	4-Ø19	140	80	Δ
	1"x3/4"	25	19	25	165	125	89	51	2	16	4-Ø19	140	86	Δ
	1 1/4"x1"	32	25	32	178	135	98.5	64	2	17.5	4-Ø19	180	98	Δ
	1 1/2"x1 1/4"	40	32	38	190	155	114.5	73	2	19.5	4-Ø22	180	106	Δ
	2"x1 1/2"	50	38	51	216	165	127	92	2	21	8-Ø19	200	133	11
	3"x2"	80	51	76	283	210	168.5	127	2	27	8-Ø22	300	138	21
	4"x3"	100	76	102	305	255	200	157	2	30.5	8-Ø22	650	175	36
	6"x4"	150	102	152	403	320	270	216	2	35	12-Ø22	800	235	82
8"x6"	200	152	203	419	380	330	270	2	40	12-Ø25	1000	285	126	

Please consult the factory:

Note: The weight value in only for flanged valve. Please consult our factory for higher nominal diameter or weight. Any modification to sizes H, H1 and weight will not be notified otherwise.

1PC Body Floating Ball Valve

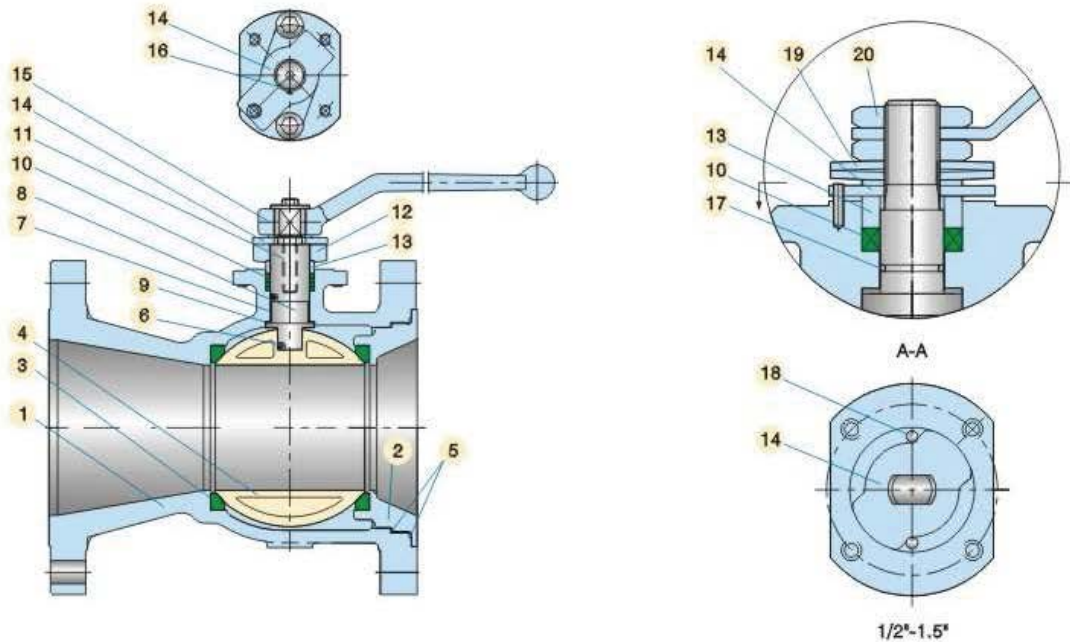

Item	Part Name	Material
1	Body	ASTM A216 GR.WCB
2	Closure	ASTM A216 GR.WCB
3	Ball Seat	R-PTFE
4	Ball	ASTM A182 F316
5	Body Gasket	316+ Graphite
6	Antistatic Device	ASTM A276 Type 316
7	Stem Bearing	PTFE
8	Stem	ASTM A182 F316
9	Thrust Washer	PTFE
10	Stem Packing	Flexidle Graphite
11	Socket Heat Bolt	ASTM A193 GR.B7
12	Gland Flange	Carbon Steel
13	Gland	ASTM A276 Type 316
14	Stop Plate	Carbon Steel
15	Lever	ASTM A216 GR.WCB
16	Retaining Ring	ASTM A686-W1
17	O-Ring	VITON
18	Stop Pin	Harmonic Steel
19	Washer Spring	Harmonic Steel
20	Nut	Carbon Steel

◆ Features

Size: 1/2"-6"
Class:150-300
One Piece Cast Steel Body
Floating Ball
Reduced Bore
Anti-Static Device
Blow-out Proof Stem
Fire Safe Design
ASME B16.34

◆ Specification

Design	ASME B16.34/API608
Face to Face	ASME B16.10
End Flange	ASME B16.5
Test	API598
Fire Safe Test	API607/6FA
Special	MACE MR-01-75

Note: The material is only for WCB body, Please consult SKVAL for other material.

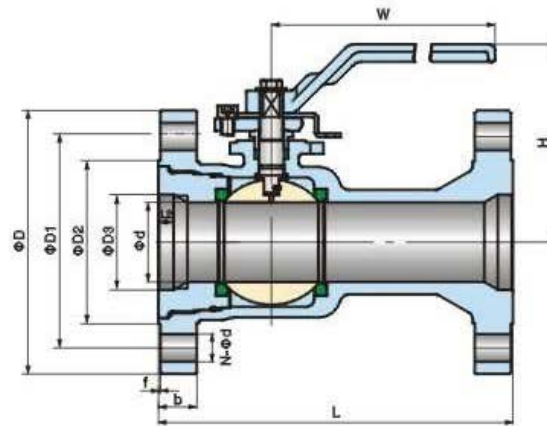

Pressure Rating	Nominal Diameter		d	d1	Flanged L(RF)	Raised Face Flange						W	Cast Steel	Weight (kg)
	Class	NPS				DN	D	D1	D2	f	b		N-φd	H
150		3/4"x1/2"	20	13	117	100	70	43	2	10	4-φ16	140	80	Δ
		1"x3/4"	25	19	127	110	79.5	51	2	11	4-φ16	140	86	Δ
		1 1/4"x1"	32	25	140	115	89	64	2	11	4-φ16	180	98	Δ
		1 1/2"x1 1/4"	40	32	165	125	98.5	73	2	13	4-φ16	180	106	Δ
		2"x1 1/2"	50	38	178	150	120.5	92	2	14.5	4-φ19	200	133	8
		3"x2"	80	50	203	190	152.5	127	2	17.5	4-φ19	300	138	14
		4"x3"	100	75	229	230	190.5	157	2	22.5	8-φ19	650	175	24
		6"x4"	150	100	267	280	241.5	216	2	24	8-φ22	800	235	41
300		3/4"x1/2"	20	13	152	115	82.5	43	2	14.5	4-φ19	140	80	Δ
		1"x3/4"	25	19	165	125	89	51	2	16	4-φ19	140	86	Δ
		1 1/4"x1"	32	25	178	135	98.5	64	2	17.5	4-φ19	180	98	Δ
		1 1/2"x1 1/4"	40	32	190	155	114.5	73	2	19.5	4-φ22	180	106	Δ
		2"x1 1/2"	50	38	216	165	127	92	2	21	8-φ19	200	133	11
		3"x2"	80	50	283	210	168.5	127	2	27	8-φ22	300	138	21
		4"x3"	100	75	305	255	200	157	2	30.5	8-φ22	650	175	36
		6"x4"	150	100	403	320	270	216	2	35	12-φ22	800	235	82
	8"x6"	200	150	419	380	330	270	2	40	12-φ25	1000	285	126	

Please consult the factory:

Note: The weight value is only for flanged valves. Please consult our factory for higher nominal diameter or weight. Any modification to sizes H, H1 and weight will not be notified otherwise.

3PCS Body Floating Ball Valve

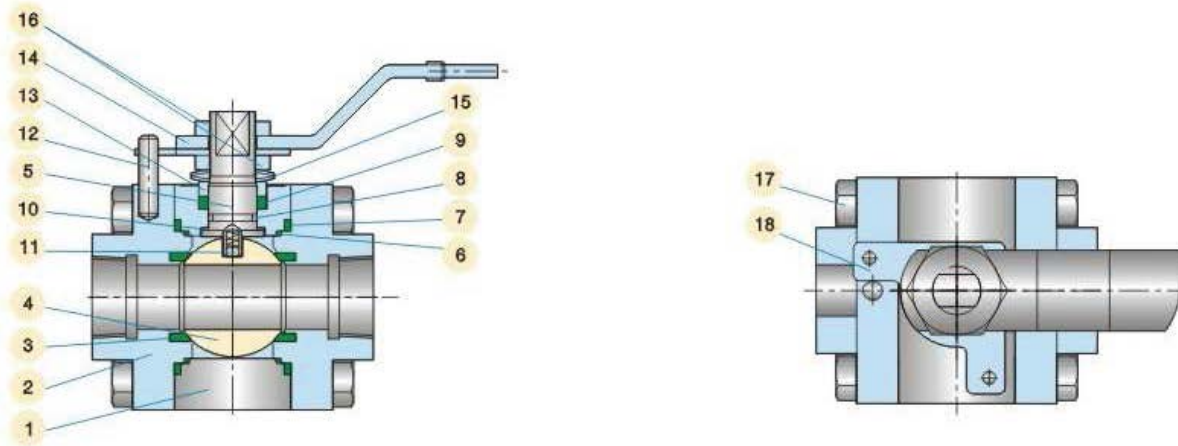

◆ Notes

- 1. Basic Design I/A/W Applicable Requirements of API608 Specification.
- 2. Wall Thickness I/A/W API600;
- 3. Pressure Tests I/A/W API598&API 6D;
- 4. Anti-static Devices I/A/W API6D;
- 5. Fire Safe Design To API 607;
- 6. The End Thread In Accordance With AMSE B1.20.1
- 7. The End Socket Weld In Accordance With AMSE B16.11.

◆ Parts & Material List

Item	Part Name	A105/316	A105/304	F316/316	LF2/316
1	Body	ASTM A105	ASTM A105	ASTM A182 F316	ASTM A350 LF2
2	End Piece	ASTM A105	ASTM A105	ASTM A182 F316	ASTM A350 LF2
3	Ball Seat	TEFLON	TEFLON	TEFLON	TEFLON
4	Ball	ASTM A182 F316	ASTM A182 F304	ASTM A182 F316	ASTM A182 F316
5	Stem	ASTM A182 F316	ASTM A182 F304	ASTM A182 F316	ASTM A182 F316
6	Spacer	PTFE	PTFE	PTFE	PTFE
7	Firesafe Gasket	316+Graphite	316+Graphite	316+Graphite	316+Graphite
8	O-Ring	VITON	VITON	VITON	VITON
9	Stem Packing	Graphite	Graphite	Graphite	Graphite
10	Thrust Bearing	R-PTFE	R-PTFE	R-PTFE	R-PTFE
11	Antistatic Device	ASTM A276 Type 316	ASTM A276 Type 316	ASTM A276 Type 316	ASTM A276 Type 316
12	Pin	Carbon Steel	Carbon Steel	Stainless Steel	Stainless Steel
13	Gland	ASTM A276 Type 316	ASTM A276 Type 316	ASTM A276 Type 316	ASTM A276 Type 316
14	Lever	Carbon Steel	Carbon Steel	Stainless Steel	Stainless Steel
15	Washer Spring	Harmonic Steel	Harmonic Steel	Harmonic Steel	Harmonic Steel
16	Stem Nut	Carbon Steel	Carbon Steel	Stainless Steel	Stainless Steel
17	Bolt	B7	B7	B8	L7M
18	Stop Plate	Carbon Steel	Carbon Steel	Carbon Steel	Carbon Steel

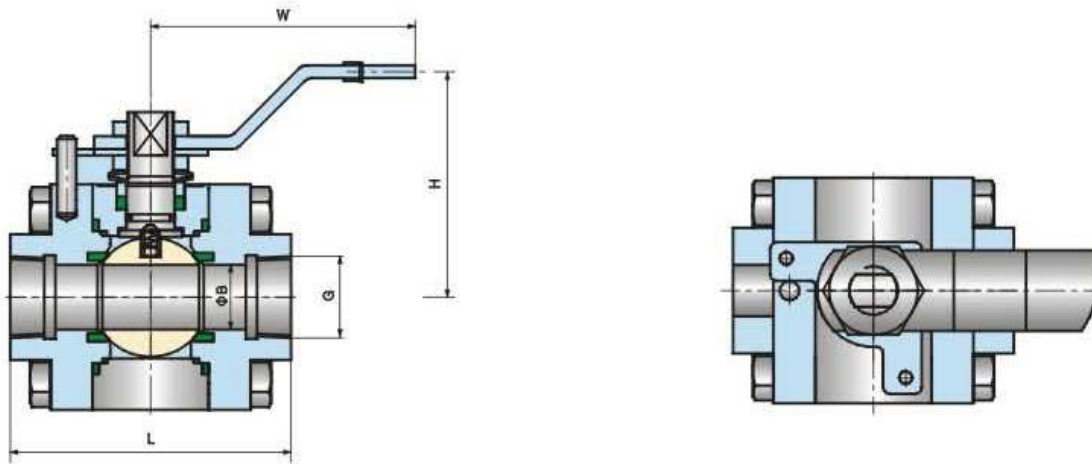

Pressure Rating	Size	Dimension IN mm.					WT kg's
		L	H	ΦB	G	W	
800 LB	1/2"	75	65	15	1/2"	155	1.2
	3/4"	87	70	20	3/4"	170	2.6
	1"	120	75	25	1"	170	3.5
	1 1/4"	120	88	32	1 1/4"	230	5.0
	1 1/2"	140	120	38	1 1/2"	220	7.0
	2"	160	175	50	2"	310	11.0

Pressure Rating	Size	Dimension IN mm.					WT kg's
		L	H	ΦB	G	W	
1500 LB	3/8"	87	65	10	1/2"	155	1.0
	1/2"	87	65	15	1/2"	155	1.2
	3/4"	110	76	20	3/4"	170	3.1
	1"	120	75	25	1"	170	3.5
	1 1/2"	160	124	40.2	1 1/2"	230	5.0
	2"	200	175	51	2"	280	8.5

DOUBLE BLOCK AND BLEED VALVE SERIES (TWIN BALL DESIGN)



Double Block And Bleed Valve (Twin Ball Design)

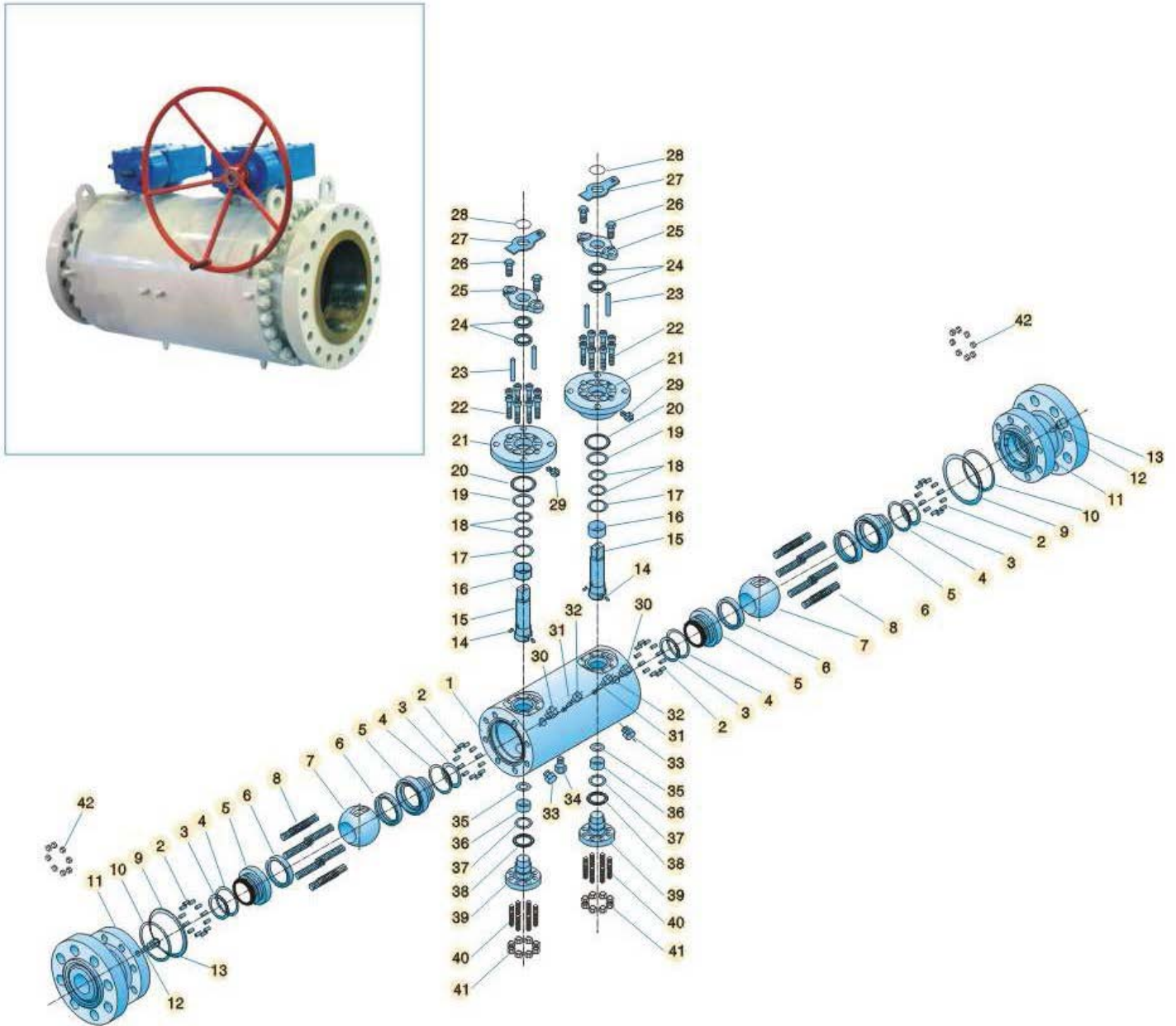

◆ Double Block And Bleed Valve (Twin Ball Design)

1	2	3	4	5	6	7	8	9	10	11	12	13	14
Body	Spring	Anti-fire Packing	O-ring	Seat Ring	Seat	Ball	Stud	Anti-fire Gasket	O-ring	Tallpiece	Check Valve	Sealant Injection Valve	Anti-static Device
15	16	17	18	19	20	21	22	23	24	25	26	27	28
Stem	Sliding Bearing	Thrust Bearing	O-ring	O-ring	Anti-fire Gasket	Seal Gland	Socket Head Cap Screw	Pin	Packing	Packing Gland	Hexagon Bolt	Stopper	Retainer Ring
29	30	31	32	33	34	35	36	37	38	39	40	41	42
Stem Injection Fitting	Vent Valve	Check Valve	Seat Injection Fitting	Drain Valve	Drain Valve	Thrust Bearing	Sliding Bearing	O-ring	Anti-fire Gasket	Trunnion	Stud	Hexagon Nut	Hexagon Nut

◆ Part Materials And Main Parameters

Nominal Diameter (in)		NPS 2-16				
Nominal Pressure (MPa)		Class150~Class2500				
No.	Part Name	Material				
		Carbon steel	Stainless steel			
1	Body	ASTM A105	ASTM A182 304	ASTM A182 316	ASTM A182 304L	ASTM A182 316L
2	Spring	INCONEL X750				
3	Anti-fire Packing	Graphite				
4	O-Ring	VITON	VITON	VITON	VITON	VITON
5	Seat Ring	ASTM A105 · ENP	ASTM A182 304	ASTM A182 316	ASTM A182 304L	ASTM A182 316L
6	Seat	PTFE/NYLON/PEEK/PPL				
7	Ball	ASTM A105 · ENP	ASTM A182 304	ASTM A182 316	ASTM A182 304L	ASTM A182 316L
8	Stud	A193 B7M	A320 B8	A320 B8M	A320 B8	A320 B8M
9	Anti-fire Gasket	SST+Graphite				
10	O-Ring	VITON				
11	Tailpiece	ASTM A105	ASTM A182 304	ASTM A182 316	ASTM A182 304L	ASTM A182 316L
12	Check Valve	Combined parts	Combined parts	Combined parts	Combined parts	Combined parts
13	Sealant Injection Valve	Combined parts	Combined parts	Combined parts	Combined parts	Combined parts
14	Anti-static Device	Combined parts	Combined parts	Combined parts	Combined parts	Combined parts
15	Stem	ASTM A182 F6a	ASTM A182 304	ASTM A182 316	ASTM A182 304L	ASTM A182 316L
16	Sliding Bearing	Metal+PTFE	Metal+PTFE	Metal+PTFE	Metal+PTFE	Metal+PTFE
17	Thrust Bearing	PTFE				
18	O-Ring	VITON				
19	O-Ring	VITON				
20	Anti-fire Gasket	SST+Graphite				
21	Seal Gland	ASTM A105 · ENP	ASTM A182 304	ASTM A182 316	ASTM A182 304L	ASTM A182 316L
22	Socket head cap screw	A193 B7M	A320 B8	A320 B8M	A320 B8	A320 B8M
23	Pin	ANSI 1035	ANSI 1035	ANSI 1035	ANSI 1035	ANSI 1035
24	Packing	Graphite	Graphite	Graphite	Graphite	Graphite
25	Packing Gland	ASTM A216 WCB	ASTM A216 WCB	ASTM A216 WCB	ASTM A216 WCB	ASTM A216 WCB
26	Hexagon Bolt	A193 B7M	A320 B8	A320 B8M	A320 B8	A320 B8M
27	Stopper	A3 · HZn	A3 · HZn	A3 · HZn	A3 · HZn	A3 · HZn
28	Retainer Ring	65Mn	65Mn	65Mn	65Mn	65Mn
29	Stem Injection Fitting	Combined parts	Combined parts	Combined parts	Combined parts	Combined parts
30	Vent Valve	Combined parts	Combined parts	Combined parts	Combined parts	Combined parts
31	Check Valve	Combined parts	Combined parts	Combined parts	Combined parts	Combined parts
32	Seat Injection Fitting	Combined parts	Combined parts	Combined parts	Combined parts	Combined parts
33	Drain Valve	Combined parts	Combined parts	Combined parts	Combined parts	Combined parts
34	Drain Valve	Combined parts	Combined parts	Combined parts	Combined parts	Combined parts
35	Thrust Bearing	PTFE				
36	Sliding Bearing	Metal+PTFE	Metal+PTFE	Metal+PTFE	Metal+PTFE	Metal+PTFE
37	O-Ring	VITON				
38	Anti-fire Gasket	SST+Graphite				
39	Trunnion	ASTM A105 · ENP	ASTM A182 304	ASTM A182 316	ASTM A182 304L	ASTM A182 316L
40	Stud	A193 B7M	A320 B8	A320 B8M	A320 B8	A320 B8M
41	Hexagon Nut	A194-2HM	A194-8	A194-8M	A194-8	A194-8M
42	Hexagon Nut	A194-2HM	A194-8	A194-8M	A194-8	A194-8M
Applicable Service Conditions	Applicable Media	Water, steam, oil, gas, liquefied gas, natural gas, etc.	Nitric acid	Acetic acid	Strong Oxidizer	Urea
	Applicable Temperature	120°C(PTFE)、≤80°C(NYLON)、≤250°C(PEEK)、≤250°C(PPL)				
Design And Manufacturing		API 608, API 6D				
Face-to-face Dimensions		ASME B16.10, API 6D				
Type Of Connection		Flange	ASME B16.5/ASME B16.47		Butt welding	ASME B16.25
Pressure Test		API 598, API6D				
Transmission Mode		Manual, worm and worm gear transmission, pneumatic, electric				

TOP ENTRY BALL VALVE SERIES



Forged Steel Top Entry Ball Valve

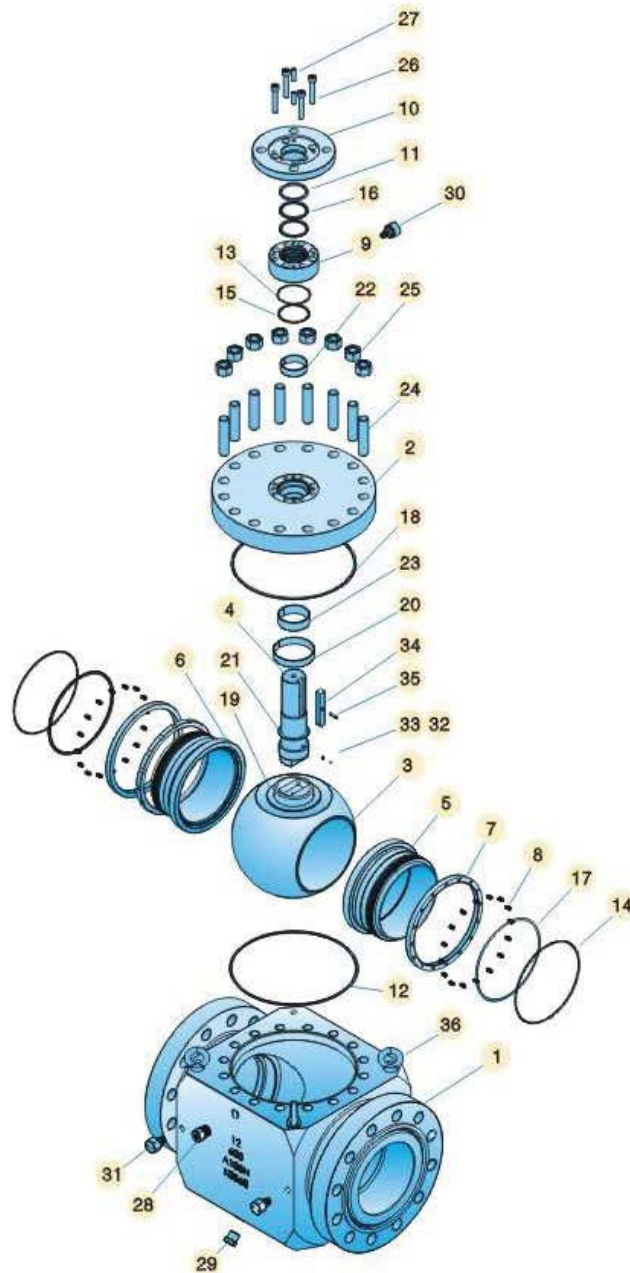
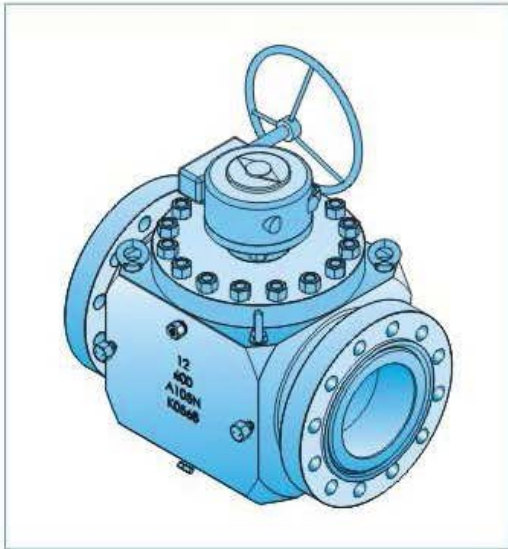

◆ Forged Steel Top Entry Ball Valve

1	2	3	4	5	6	7	8	9	10	11	12
Body	Cover	Ball	Stem	Seat Ring	Seat Insert	Spring Plate	Spring	Gland	Gland Plate	Stem Packing	Anti-fire Gasket
13	14	15	16	17	18	19	20	21	22	23	24
Anti-fire Gasket	O-ring	O-ring	O-ring	O-ring	O-ring	Ball Thrust Bearing	Ball DU Bearing	Stem Thrust Bearing	Stem DU Bearing	End Adapter DU Bearing	Body Stud
25	26	27	28	29	30	31	32	33	34	35	36
Body Nut	Gland Screw	Pin	Vent Valve	Plug	Stem Injection Fitting	Seat Injection Fitting	Anti-static Ball	Anti-static Spring	Key	Spring Pin Slotted	Lug

◆ Part Materials and Main Parameters

Item	Part Name	Material	Material	Material
		A105N	A105N+ENP	F316
1	Body	ASTM A105N	ASTM A105N	ASTM A182 F316
2	End Adapter	ASTM A105N	ASTM A105N	ASTM A182 F316
3	Ball	ASTM A182 F316	ASTM A105N+ENP	ASTM A182 F316
4	Stem	ASTM A182 F316	ASTM A105N+ENP	ASTM A182 F316
5	Seat Ring	ASTM A182 F316	ASTM A105N+ENP	ASTM A182 F316
6	Seat Insert	RPTFE	RPTFE	RPTFE
7	Spring Plate	ASTM A182 F316	ASTM A105N+ENP	ASTM A182 F316
8	Spring	Inconel X750	Inconel X750	Inconel X750
9	Gland	ASTM A105N	ASTM A105N	ASTM A182 F316
10	Gland Plate	ASTM A105N	ASTM A105N	ASTM A182 F316
11	Stem Packing	Graphite	Graphite	Graphite
12	Anti-fire Gasket	S.P.W.316+Graphite	S.P.W.316+Graphite	S.P.W.316+Graphite
13	Anti-fire Gasket	S.P.W.316+Graphite	S.P.W.316+Graphite	S.P.W.316+Graphite
14	O-Ring	Viton	Viton	Viton
15	O-Ring	Viton	Viton	Viton
16	O-Ring	Viton	Viton	Viton
17	O-Ring	Viton	Viton	Viton
18	O-Ring	Viton	Viton	Viton
19	Ball Thrust Bearing	AISI 1045+PTFE	AISI 1045+PTFE	AISI 1045+PTFE
20	Ball DU Bearing	AISI 1045+PTFE	AISI 1045+PTFE	AISI 1045+PTFE
21	Stem Thrust Bearing	AISI 1045+PTFE	AISI 1045+PTFE	AISI 1045+PTFE
22	Stem DU Bearing	AISI 1045+PTFE	AISI 1045+PTFE	AISI 1045+PTFE
23	End Adapter DU Bearing	AISI 1045+PTFE	AISI 1045+PTFE	AISI 1045+PTFE
24	Body Stud	ASTM A193 B7	ASTM A193 B7	ASTM A193 B8
25	Body Nut	ASTM A194 2H	ASTM A194 2H	ASTM A194 8
26	Gland Screw	ASTM A193 B7	ASTM A193 B7	ASTM A193 B8
27	Pin	AISI 1045	AISI 1045	AISI 1045
28	Vent Valve	ASTM A105N	ASTM A105N	ASTM A182 F316
29	Plug	SS316	SS316	SS316
30	Sealant Injection Fitting Assembly	ASTM A105N	ASTM A105N	ASTM A182 F316
31	Sealant Injection Fitting Assembly	ASTM A105N	ASTM A105N	ASTM A182 F316
32	Anti-static Ball	SS316	SS316	SS316
33	Anti-static Spring	SS316	SS316	SS316
34	Key	SS316	SS316	SS316
35	Spring Pin Slotted	SS316	SS316	SS316
36	Lug	Carbon Steel	Carbon Steel	Carbon Steel

Cast Steel Top Entry Ball Valve

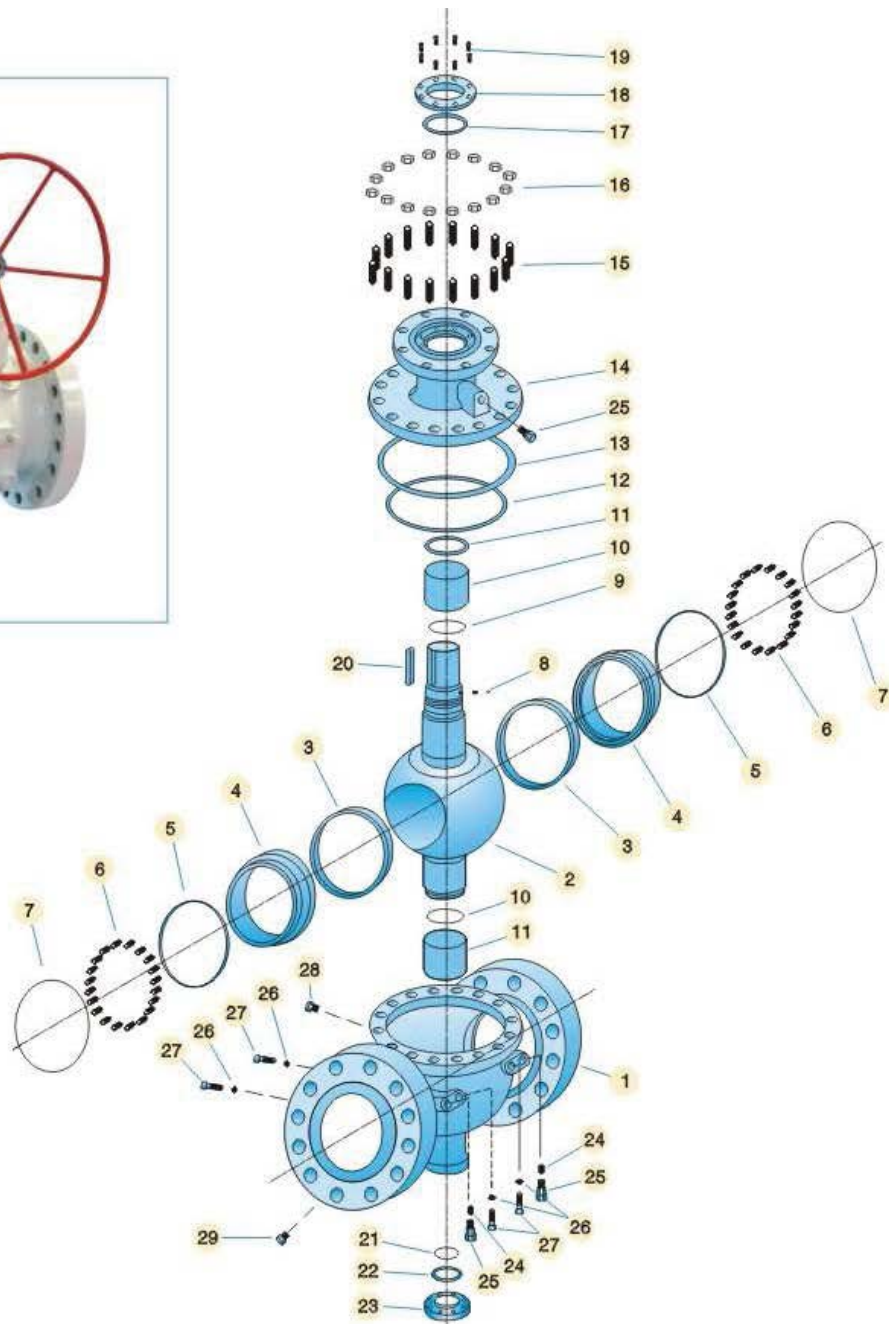

◆ Cast Steel Top Entry Ball Valve

1	2	3	4	5	6	7	8	9	10
Body	Ball	Seat	Seat Ring	O-Ring	Spring	Anti-fire Packing	Anti-static Device	O-Ring	Sliding Bearing
11	12	13	14	15	16	17	18	19	20
Thrust Bearing	O-Ring	Anti-fire Gasket	End Adapter	Stud	Hexagon Nut	Packing	Packing Gland	Socket Head Cap Screw	Fly Key
21	22	23	24	25	26	27	28	29	
Thrust Bearing	Anti-fire Gasket	Lower Cover	Check Valve	Sealant Injection valve	Sealing Gasket	Socket Head Cap Screw	Air Release Valve	Drainage Valve	

◆ Part Materials and Main Parameters

Nominal Diameter (In)		NPS 2-36				
Nominal Pressure (MPa)		Class150~Class900				
No.	Part Name	Material				
		Carbon steel	Stainless steel			
1	Body	ASTM A216 WCB	ASTM A351 CF8	ASTM A351 CF8M	ASTM A351 CF3	ASTM A351 CF3M
2	Ball	ASTM A105 · ENP	ASTM A182 304	ASTM A182 316	ASTM A182 304L	ASTM A182 316L
3	Seat	PTFE/NYLON/PEEK/PPL				
4	Seat Ring	ASTM A105 · ENP	ASTM A182 304	ASTM A182 316	ASTM A182 304L	ASTM A182 316L
5	O-Ring	VITON				
6	Spring	INCONEL X750				
7	Anti-fire Packing	Graphite				
8	Anti-static Device	Combined parts	Combined parts	Combined parts	Combined parts	Combined parts
9	O-Ring	VITON				
10	Sliding Bearing	Metal+PTFE	Metal+PTFE	Metal+PTFE	Metal+PTFE	Metal+PTFE
11	Thrust Bearing	PTFE				
12	O-Ring	VITON				
13	Anti-fire Gasket	SST+Graphite				
14	End Adapter	ASTM A216 WCB	ASTM A351 CF8	ASTM A351 CF8M	ASTM A351 CF3	ASTM A351 CF3M
15	Stud	A193 B7M	A320 B8	A320 B8M	A320 B8	A320 B8M
16	Hexagon Nut	A194-2HM	A194-8	A194-8M	A194-8	A194-8M
17	Packing	Graphite				
18	Packing Gland	ASTM A105 · ENP	ASTM A182 304	ASTM A182 316	ASTM A182 304L	ASTM A182 316L
19	Socket Head Cap Screw	A193 B7M	A320 B8	A320 B8M	A320 B8	A320 B8M
20	Fly Key	ANSI 1045	ANSI 1045	ANSI 1045	ANSI 1045	ANSI 1045
21	Thrust Bearing	PTFE				
22	Anti-fire Gasket	SST+Graphite				
23	Lower Cover	ASTM A105 · ENP	ASTM A182 304	ASTM A182 316	ASTM A182 304L	ASTM A182 316L
24	Check Valve	Combined parts	Combined parts	Combined parts	Combined parts	Combined parts
25	Sealant Injection Valve	Combined parts	Combined parts	Combined parts	Combined parts	Combined parts
26	Sealing Gasket	SST+Graphite				
27	Socket Head Cap Screw	A193 B7M	A320 B8	A320 B8M	A320 B8	A320 B8M
28	Air Release Valve	Combined parts	Combined parts	Combined parts	Combined parts	Combined parts
29	Drainage Valve	Combined parts	Combined parts	Combined parts	Combined parts	Combined parts
Applicable Service Conditions	Applicable Media	Water, steam, oil, gas, liquefied gas, natural gas, etc.	Nitric acid	Acetic acid	Strong Oxidizer	Urea
	Applicable Temperature	120°C(PTFE)、≤80°C(NYLON)、≤250°C(PEEK)、≤250°C(PPL)				
Design And Manufacturing		API 608、API 6D				
Face-to-face Dimensions		ASME B16.10、API 6D、JIS B2002				
Type Of Connection		Flange	ASME B16.5/ASME B16.47		Butt welding	ASME B16.25
Pressure Test		API 598、API6D				
Transmission Mode		Manual, gear, pneumatic, electric				

CRYOGENIC BALL VALVE SERIES



Cryogenic Ball Valve

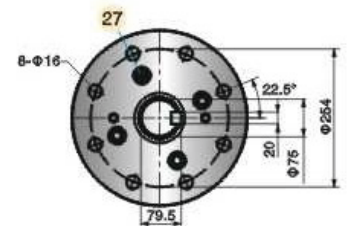
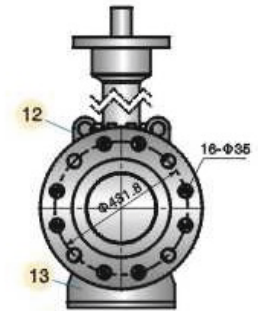
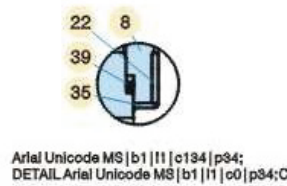
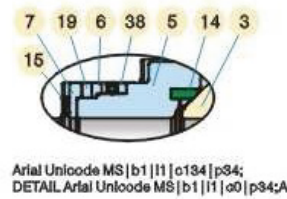
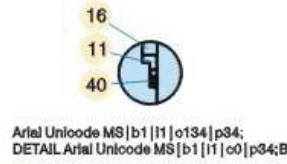
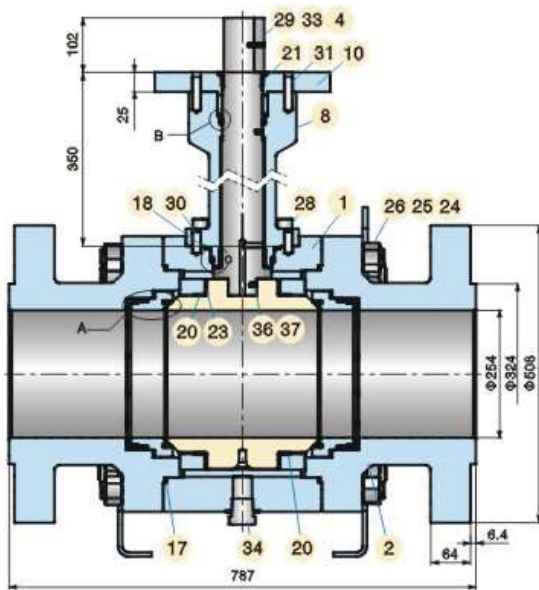

Item	Part Name	Material	Qty.
1	Body	ASTM A182-F316	1
2	Tallpiece	ASTM A182-F316	2
3	Ball	ASTM A182-F316	1
4	Stem	ASTM A182-F316	1
5	Seat	ASTM A182-F316	2
6	Seat LPS Plate	ASTM A182-F316	2
7	Seat Graphite Plate	ASTM A182-F316	2
8	Gland	ASTM A182-F316	1
9	Bearing Plate	ASTM A182-F316	2
10	Gland Plate	ASTM A182-F316	1
11	Gland Ring	ASTM A182-F316	1
12	Lug	Stainless Steel	2
13	Leg	Stainless Steel	2
14	Seat Insert	PCTFE	2
15	Seat Spring	Inconel X750	24
16	Stem Packing	Graphite	1
17	Body Gasket	SPW.316+Graphite	2
18	Gland Gasket	SPW.316+Graphite	1
19	Seat Fire-safe gasket	Graphite	2
20	DU Thrust Bearing	316 S/S+PTFE	2

Item	Part Name	Material	Qty.
21	Bearing	PTFE	1
22	DU Bearing	316 S/S+PTFE	1
23	DU Bearing	316 S/S+PTFE	2
24	Body Studs	ASTM A193-B8M	6
25	Body Studs	ASTM A193-B8M	26
26	Body Nuts	ASTM A194-8M	32
27	Gland Plate Screw	ASTM A193-B8M	4
28	Gland Screw	ASTM A193-B8M	8
29	Key	AISI 1045	1
30	Pin	AISI 316 S/S	2
31	Pin	AISI 316 S/S	2
32	Pin	AISI 316 S/S	8
33	Spring Pin	AISI 1566	1
34	Plug	AISI 316 S/S	1
35	Thrust Bearing	PTFE	1
36	Anti-Static Ball	AISI 316 S/S	2
37	Anti-Static Spring	AISI 316 S/S	2
38	Lipseal	Alloy + PTFE	2
39	Lipseal	Alloy + PTFE	1
40	Lipseal	Alloy + PTFE	1

Notes:

1. Basic Design I/A/W Applicable Requirements Of ASME/ANSI B16.34 And API 6D Specification;
2. Ends Flanged & Drilled I/A/W ASME/ANSI B16.5;
3. Face To Face Dimensions I/A/W ASME/ANSI B16.10;

4. Pressure Tests I/A/W API598;
5. Anti-static Devices I/A/W API6D;
6. The Product I/A/W API 607.
7. Materials Comply With Nace MR-0175;
8. The Valve Shall Be Used Cryogenic Service -185°C.

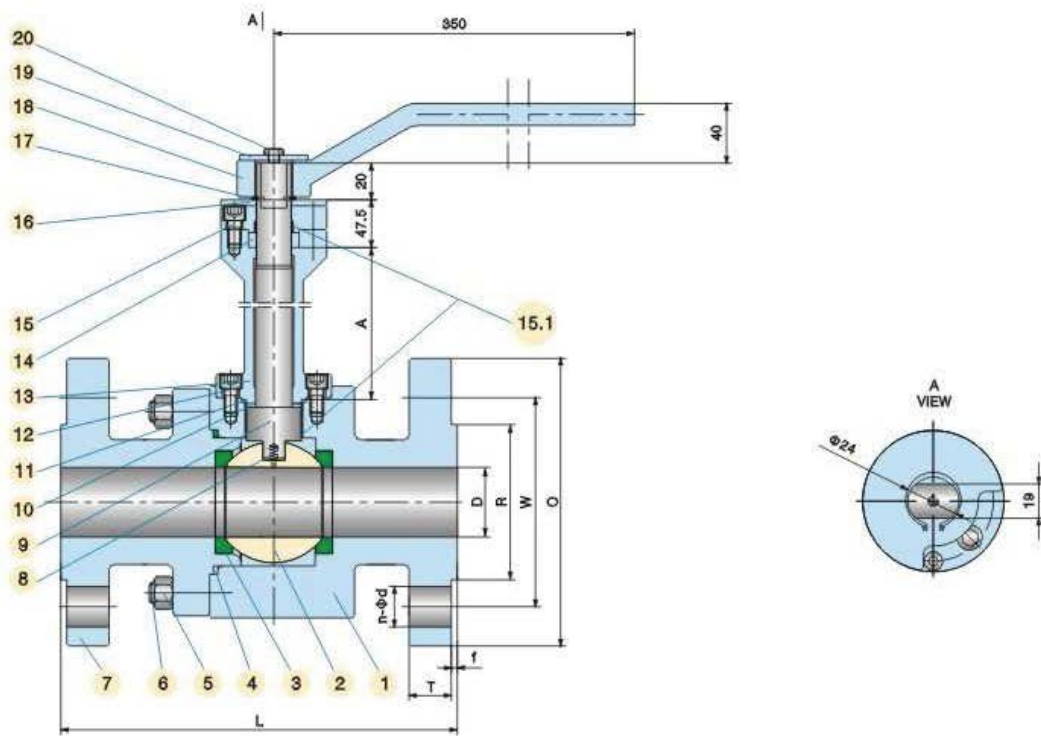

Item	Part Name	Material
1	Body	A182 F316
2	Ball	A182 F316
3	Seat	PCTFE
4	Gasket	316+Graphite
5	Nut	A194 8M
6	Bolt	A320 B8M
7	End Flange	A182 F316
8	Spring	A276 304
9	Stem	A182 F316
10	Gasket	PTFE
11	Gasket	Graphite+316
12	Bolt	A320 B8M
13	Yoke	A182 F316
14	Packing	PTFE
15	Bolt	A193 B8M
15.1	Bearing	316+PTFE
16	Stop Plate	Stainless steel
17	Retaining Ring	A686-W1
18	Handle	Stainless steel
19	Plate	Stainless steel
20	Bolt	Stainless steel

METAL SEATED BALL VALVE SERIES

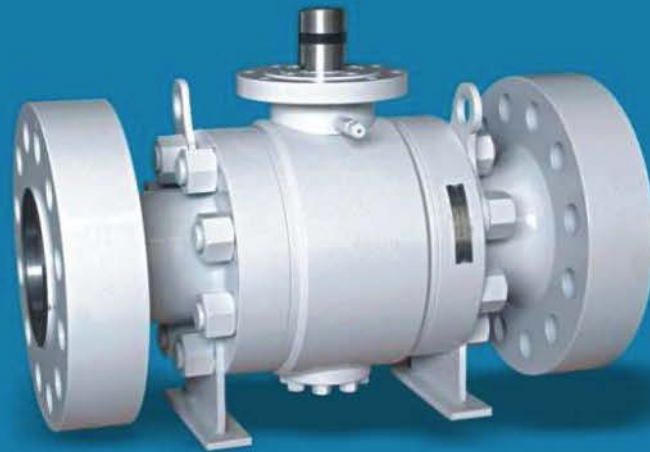

◆ Part Materials and Main Parameters

Nominal Diameter (In)		NPS 1/2~8				
Nominal Pressure (MPa)		Class 150~Class 600				
No.	Part Name	Material				
		Carbon Steel	Stainless Steel			
1	Body	ASTM A105	ASTM A182 304L	ASTM A182 316	ASTM A182 304	ASTM A182 316L
2	End Adapter	ASTM A105	ASTM A182 304L	ASTM A182 316	ASTM A182 304	ASTM A182 316L
3	Ball	ASTM A105+HF	ASTM A182 304L+HF	ASTM A182 316+HF	ASTM A182 304+HF	ASTM A182 316L+HF
4	Stem	ASTM A182 F6a	ASTM A182 304L	ASTM A182 316	ASTM A182 304	ASTM A182 316L
5	Seat	ASTM A105+HF	ASTM A182 304L+HF	ASTM A182 316+HF	ASTM A182 304+HF	ASTM A182 316L+HF
6	Trunnion	ASTM A105 • CHR	ASTM A182 304L	ASTM A182 316	ASTM A182 304	ASTM A182 316L
7	Gland	ASTM A105	ASTM A182 304L	ASTM A182 316	ASTM A182 304	ASTM A182 316L
8	Spring Seat	ASTM A105 • CHR	ASTM A182 304L	ASTM A182 316	ASTM A182 304	ASTM A182 316L
9	Sealing Gasket	Graphite				
10	Packing Bushing	ASTM A182 F6a	ASTM A182 F6a	ASTM A182 F6a	ASTM A182 F6a	ASTM A182 F6a
11	Packing Gland	ASTM A216 WCB	ASTM A216 WCB	ASTM A216 WCB	ASTM A216 WCB	ASTM A216 WCB
12	Spring	INCONEL X750				
13	Stud	A193 B7M	A320 B8	A320 B8M	A320 B8	A320 B8M
14	Hexagon Nut	A194-2HM	A194-8	A194-8M	A194-8	A194-8M
15	Hexagon Bolt	A193 B7M	A320 B8	A320 B8M	A320 B8	A320 B8M
16	Hexagon Nut	A194-2H	A194-8	A194-8	A194-8	A194-8
17	Stud	A193 B7M	A320 B8	A320 B8M	A320 B8	A320 B8M
18	Socket Head Cap Screw	A193 B7M	A320 B8	A320 B8M	A320 B8	A320 B8M
19	Pin	ANSI 1035	ANSI 1035	ANSI 1035	ANSI 1035	ANSI 1035
20	Flat Key	ANSI 1045	ANSI 1045	ANSI 1045	ANSI 1045	ANSI 1045
21	Packing	Graphite				
22	Metal Wound Gasket	SST+Graphite				
23	Metal Wound Gasket	SST+Graphite				
24	Thrust Bearing	SST+Graphite				
25	Sliding Bearing	Combined parts	TF-2			
26	Vent Valve	Combined parts	Combined parts	Combined parts	Combined parts	Combined parts
27	Plug		Combined parts	Combined parts	Combined parts	Combined parts
Applicable Service Conditions	Applicable Media	Water, steam, oil, gas, liquefied petroleum gas, natural gas,	Nitric acid	Acetic acid	Strong Oxidizer	Urea
	Applicable Temperature	≤200℃				
Design And Manufacturing		API 6D				
Face-to-face Dimensions		ASME B16.10				
Type Of Connection		Flange	ASME B16.5		Butt welding	ASME B16.25
Pressure Test		API 598、API 6D				
Transmission Mode		Manual, worm and worm gear transmission, pneumatic, electric				

FULLY WELDED BALL VALVE SERIES

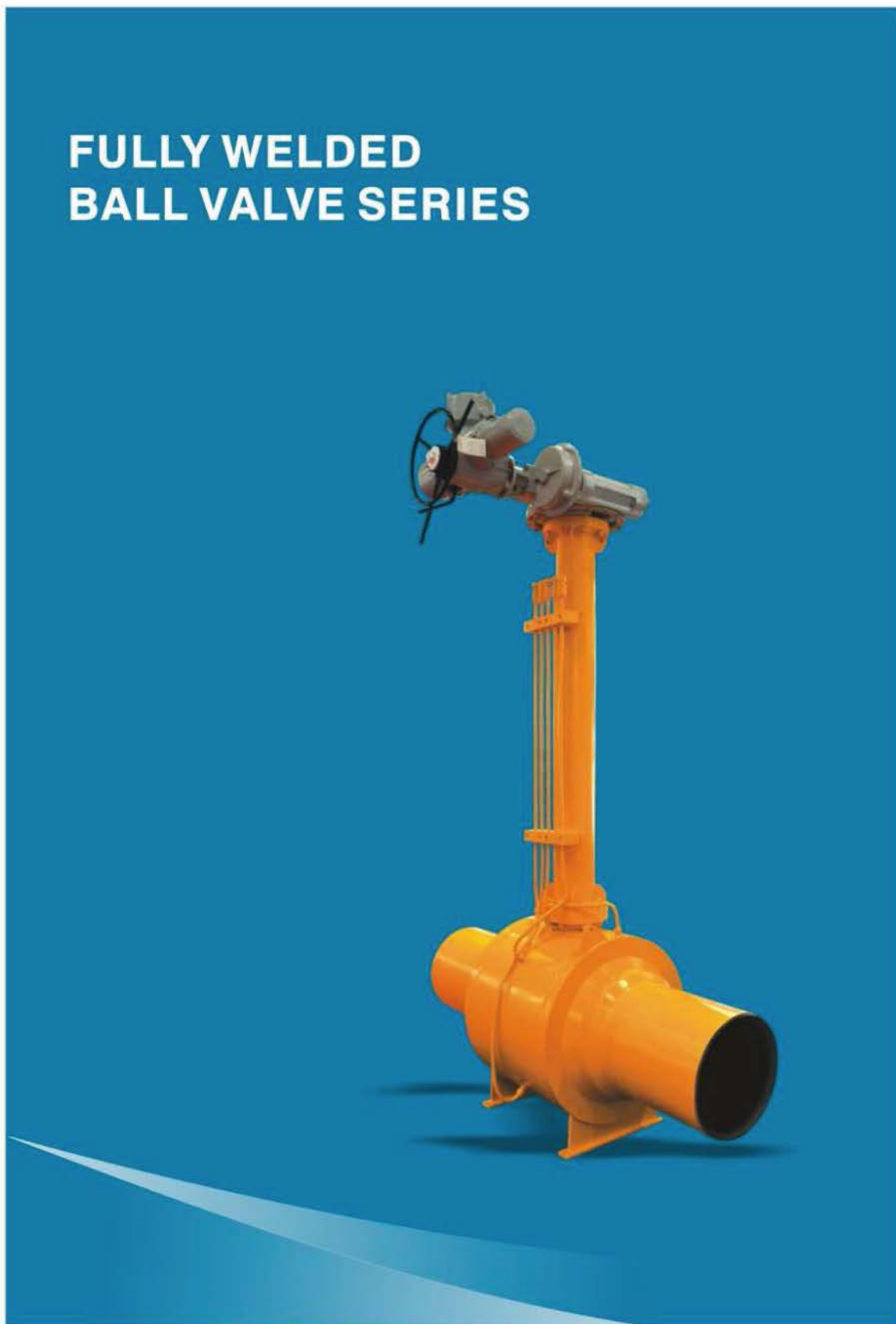

Fully Welled Ball Valve

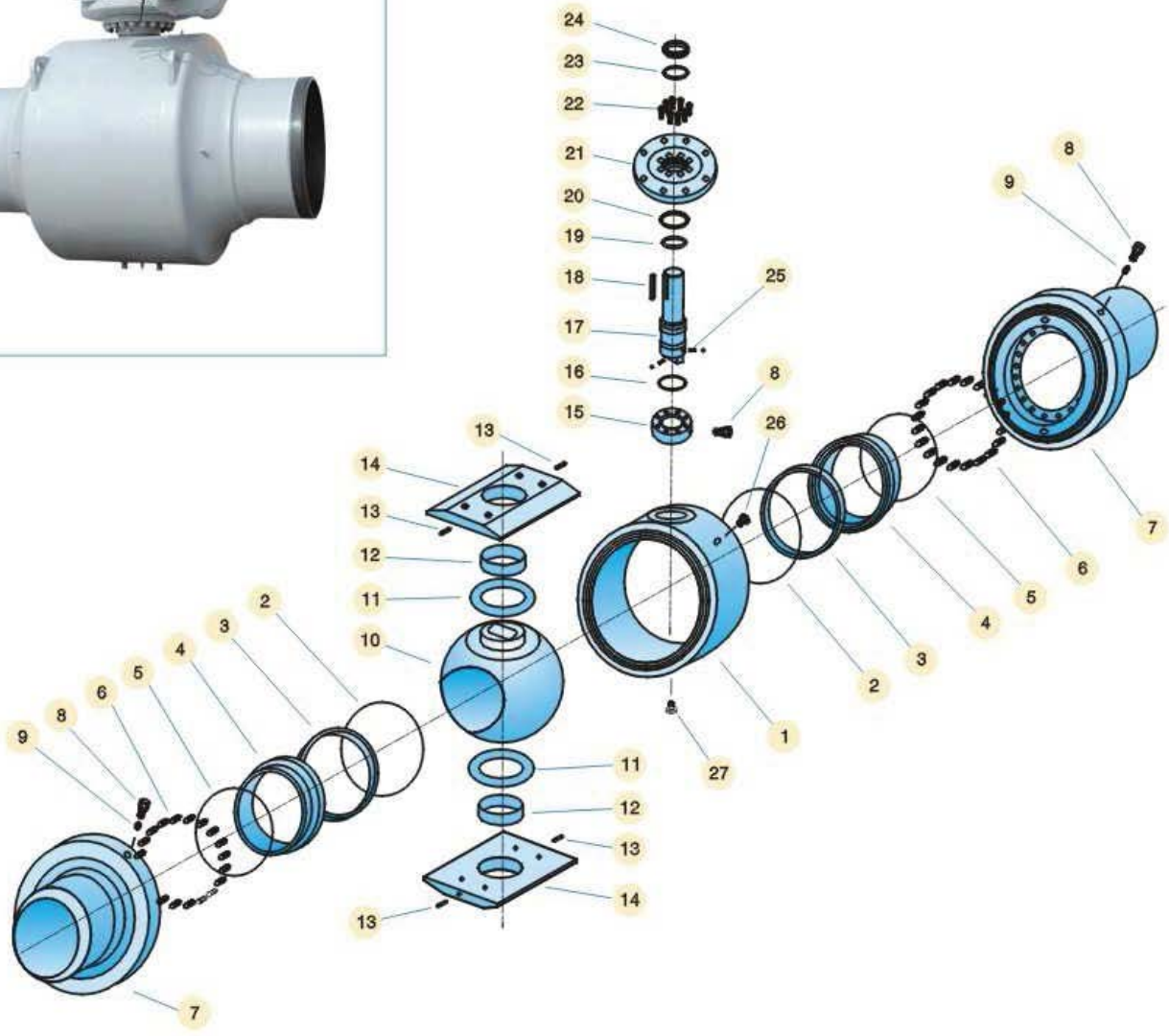

◆ Fully Welled Ball Valve

1	2	3	4	5	6	7	8	9	10	11	12	13	14
Body	Anti-fire Packing	Seat	Seat Ring	O-ring	Spring	Tailpiece	Stem Injection Fitting	Check Valve	Ball	Thrust Gasket	Sliding Bearing	Pin	Bearing Holder
15	16	17	18	19	20	21	22	23	24	25	26	27	
Seal Gland	Thrust Bearing	Stem	Flat Key	Thrust Bearing	Anti-fire Gasket	Connection Plate	Socket Head Cap Screw	Packing	Packing Gland	Anti-static Device	Vent Valve	Plug	

◆ Part Materials and Main Parameters

Nominal Diameter (in)		NPS 6~40				
Nominal Pressure (MPa)		Class150~Class1500				
No.	Part Name	Materials				
		Carbon steel	Stainless steel			
1	Body	ASTM A105	ASTM A182 304	ASTM A182 316	ASTM A182 304L	ASTM A182 316L
2	Anti-fire Packing	Graphite				
3	Seat	PTFE/NYLON/PEEK/PPL				
4	Seat Ring	ASTM A105 · ENP	ASTM A182 304	ASTM A182 316	ASTM A182 304L	ASTM A182 316L
5	O-ring	VITON				
6	Spring	INCONEL X750				
7	Tailpiece	ASTM A105	ASTM A182 304	ASTM A182 316	ASTM A182 304L	ASTM A182 316L
8	Stem Injection Fitting	Combined parts	Combined parts	Combined parts	Combined parts	Combined parts
9	Check Valve	Combined parts	Combined parts	Combined parts	Combined parts	Combined parts
10	Ball	ASTM A105 · ENP	ASTM A182 304	ASTM A182 316	ASTM A182 304L	ASTM A182 316L
11	Thrust Gasket	PTFE				
12	Sliding Bearing	Metal+PTFE	Metal+PTFE	Metal+PTFE	Metal+PTFE	Metal+PTFE
13	Pin	ANSI 1035	ANSI 1035	ANSI 1035	ANSI 1035	ANSI 1035
14	Bearing Holder	ASTM A105 · ENP	ASTM A182 304	ASTM A182 316	ASTM A182 304L	ASTM A182 316L
15	Seal Gland	ASTM A105 · ENP	ASTM A182 304	ASTM A182 316	ASTM A182 304L	ASTM A182 316L
16	Thrust Bearing	PTFE				
17	Stem	ASTM A182 F6a	ASTM A182 304	ASTM A182 316	ASTM A182 304L	ASTM A182 316L
18	Flat Key	ANSI 1045	ANSI 1045	ANSI 1045	ANSI 1045	ANSI 1045
19	Thrust Bearing	PTFE				
20	Anti-fire Gasket	SST+Graphite				
21	Connection Plate	ASTM A105	ASTM A182 304	ASTM A182 316	ASTM A182 304L	ASTM A182 316L
22	Socket Head Cap Screw	A193 B7M	A320 B8	A320 B8M	A320 B8	A320 B8M
23	Packing	Graphite	Graphite	Graphite	Graphite	Graphite
24	Packing Gland	ASTM A182 F6a	ASTM A182 F6a	ASTM A182 F6a	ASTM A182 F6a	ASTM A182 F6a
25	Anti-static Device	Combined parts	Combined parts	Combined parts	Combined parts	Combined parts
26	Vent Valve	Combined parts	Combined parts	Combined parts	Combined parts	Combined parts
27	Plug	Combined parts	Combined parts	Combined parts	Combined parts	Combined parts
Applicable Service Conditions	Applicable Media	Water, steam, oil, gas, liquefied, petroleum gas, natural gas	Nitric acid	Acetic acid	Strong Oxidizer	Urea
	Applicable Temperature	120°C(PTFE)、≤80°C(NYLON)、≤250°C(PEEK)、≤250°C(PPL)				
Design And Manufacturing		API 608、API 6D				
Face-to-face Dimensions		ASME B16.10、API 6D、JIS B2002				
Type Of Connection		Flange	ASME B16.5/ASME B16.47		Butt welding	ASME B16.25
Pressure Test		API 598、API6D				
Transmission Mode		Manual, worm and worm gear transmission, pneumatic, electric				

END CONNECTION DETAILS

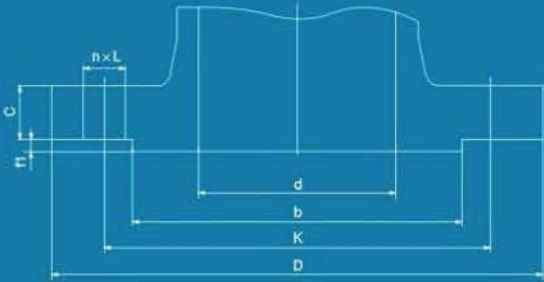

Flange Dimensions

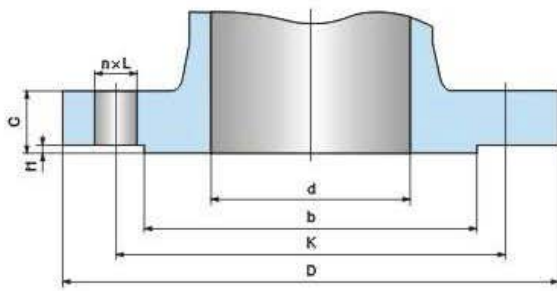

CLASS 150,300

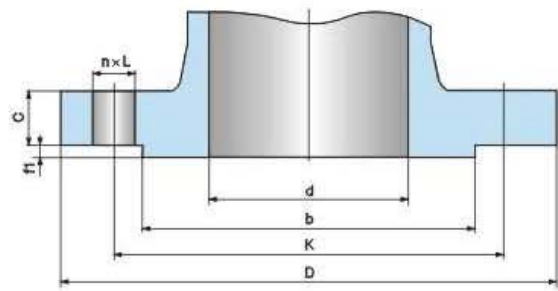

CLASS 600,900,1500,2500

◆ ASME B16.5-2003 The Flange Pipe Size

CLASS	NPS	Channel Diameter d	Flange Excircle D	Flange Thickness C (Exclude Raised Face)	Raised Face Excircle b	Raised Face f1	Drilling Centre dia.K	Holes Small-Large n-L	Face to Face Acc. To ASME B16.10		
									RF	RJ	BW
150Lb	1/2	13	89	11.5	35	1.6	60.5	4-16	108	119	140
	3/4	19	98	11.5	43	1.6	70	4-16	117	130	152
	1	25	108	12	51	1.6	79.5	4-16	127	140	165
	1 1/4	32	117	13	64	1.6	89	4-16	140	153	178
	1 1/2	38	127	15	73	1.6	98.5	4-16	165	178	191
	2	49	152	16	92	1.6	120.5	4-19	178	191	216
	2 1/2	62	178	18	105	1.6	139.5	4-19	190	203	241
	3	74	190	19	127	1.6	152.5	4-19	203	216	283
	4	100	229	24	157	1.6	190.5	8-19	229	241	305
	5	127	254	24	186	1.6	216	8-22	356	369	381
	6	150	279	26	216	1.6	241.5	8-22	394	406	457
	8	201	343	29	270	1.6	298.5	8-22	457	470	521
	10	252	406	31	324	1.6	362	12-25	533	546	559
	12	303	483	32	381	1.6	432	12-25	610	622	635
	14	334	533	35	413	1.6	476	12-29	686	699	762
	16	385	597	37	470	1.6	540	16-29	762	775	838
18	436	635	40	533	1.6	578	16-32	864	876	914	
20	487	699	43	584	1.6	635	20-32	914	927	991	
24	589	813	48	692	1.6	749.5	20-35	1067	1080	1143	
300Lb	1/2	13	95	15	35	1.6	66.5	4-16	140	151	140
	3/4	19	117	16	43	1.6	82.5	4-19	152	165	152
	1	25	124	18	51	1.6	89	4-19	165	178	165
	1 1/4	32	133	19	64	1.6	98.5	4-19	178	191	178
	1 1/2	38	156	21	73	1.6	114.5	4-22	190	203	190
	2	49	165	23	92	1.6	127	8-19	216	232	216
	2 1/2	62	190	26	105	1.6	149	8-22	241	257	241
	3	74	210	29	127	1.6	168.5	8-22	283	299	283
	4	100	254	32	157	1.6	200	8-22	305	321	305
	5	127	279	35	186	1.6	235	8-22	381	397	381
	6	150	318	37	216	1.6	270	12-22	403	419	403
	8	201	381	42	270	1.6	330	12-25	502	518	521
	10	252	445	48	324	1.6	387.5	16-29	568	584	559
	12	303	521	51	381	1.6	451	16-32	648	664	635
	14	334	584	54	413	1.6	514.5	20-32	762	778	762
	16	385	648	58	470	1.6	571.5	20-35	838	854	838
18	436	711	61	533	1.6	628.5	24-35	914	930	914	
20	487	775	64	584	1.6	686	24-35	991	1010	991	
24	589	914	70	692	1.6	813	24-41	1143	1165	1143	

◆ ASME B16.5-2003 The Flange Pipe Size

CLASS	NPS	Channel Diameter d	Flange Excircle D	Flange Thickness C (Exclude Raised face)	Raised Face Excircle b	Raised Face f1	Drilling Centre Dia.K	Holes Small-Large n-L	Face to Face Acc. To ASME B16.10		
									RF	RJ	BW
600Lb	1/2	13	95	15	35	6.4	66.5	4-16	165	163	165
	3/4	19	118	16	43	6.4	82.5	4-19	190	190	190
	1	25	124	18	51	6.4	89	4-19	216	216	216
	1 1/4	32	133	21	64	6.4	98.5	4-19	229	229	229
	1 1/2	38	156	23	73	6.4	114.5	4-22	241	241	241
	2	49	165	26	92	6.4	127	8-19	292	295	292
	2 1/2	62	190	29	105	6.4	149	8-22	330	333	330
	3	74	210	32	127	6.4	168	8-22	356	359	356
	4	100	273	38	157	6.4	216	8-25	432	435	432
	5	127	330	45	186	6.4	266.5	8-29	508	511	508
	6	150	356	48	216	6.4	292	12-29	559	562	559
	8	201	419	56	270	6.4	349	12-32	660	664	660
	10	252	508	64	324	6.4	432	16-35	787	791	787
	12	303	559	67	381	6.4	489	20-35	838	841	838
	14	334	603	70	413	6.4	527	20-38	889	892	889
	16	385	686	77	470	6.4	603	20-41	991	994	991
	18	436	743	83	533	6.4	654	20-44	1092	1095	1092
20	487	813	89	584	6.4	724	24-44	1194	1200	1194	
24	589	940	102	692	6.4	838	24-52	1397	1407	1397	
900Lb	1/2	13	121	22.5	35	6.4	82.5	4-23	216	216	216
	3/4	19	130	25.5	43	6.4	88.9	4-23	229	229	229
	1	25	149	29	51	6.4	101.6	4-26	254	254	254
	1 1/4	32	159	29	64	6.4	111.1	4-26	279	279	279
	1 1/2	38	178	32	73	6.4	123.8	4-29	305	305	305
	2	49	216	38.5	92	6.4	165.1	8-26	368	371	368
	2 1/2	62	244	41.5	105	6.4	190.5	8-29	419	422	419
	3	74	241	38.5	127	6.4	190.5	8-26	381	384	381
	4	100	292	44.5	157	6.4	234.9	8-32	457	460	457
	5	127	349	51	186	6.4	279.4	8-35	559	562	559
	6	150	381	56	216	6.4	317.5	12-32	610	613	610
	8	201	470	63.5	270	6.4	393.7	12-39	737	740	737
	10	252	545	70	324	6.4	469.9	16-39	838	841	838
	12	303	610	79.5	381	6.4	533.4	20-39	965	968	965
	14	322	640	86	413	6.4	558.8	20-42	1029	1038	1029
	16	373	705	89	470	6.4	615.9	20-45	1130	1140	1130
	18	423	785	102	533	6.4	685.8	20-51	1219	1232	1219
20	471	855	108	584	6.4	749.3	20-54	1321	1334	1321	
24	570	1040	140	692	6.4	901.7	20-67	1549	1568	1549	

◆ ASME B16.5-2003 The Flange Pipe Size

CLASS	NPS	Channel Diameter d	Flange Excircle D	Flange Thickness C (Exclude Raised face)	Raised Face Excircle b	Raised Face f1	Drilling Centre Dia.K	Holes Small-Large n-L	Face to Face Acc. To ASME B16.10		
									R F	RJ	BW
1500Lb	1/2	13	121	22.5	35	6.4	82.5	4-23	216	216	216
	3/4	19	130	25.5	43	6.4	88.9	4-23	229	229	229
	1	25	149	29	51	6.4	101.6	4-26	254	254	254
	1 1/4	32	159	29	64	6.4	111.1	4-26	279	279	279
	1 1/2	38	178	32	73	6.4	123.8	4-29	305	305	305
	2	49	216	38.5	92	6.4	165.1	8-26	368	371	368
	2 1/2	62	244	41.5	105	6.4	190.5	8-29	419	422	419
	3	74	267	48	127	6.4	203.2	8-32	470	473	470
	4	100	311	54	157	6.4	241.3	8-35	546	549	546
	5	125	375	73.5	186	6.4	292.1	8-42	673	676	673
	6	144	394	83	216	6.4	317.5	12-39	705	711	705
	8	192	483	92.9	270	6.4	393.7	12-45	832	841	832
	10	239	585	108	324	6.4	482.6	12-51	991	1000	991
	12	287	675	124	381	6.4	571.5	16-54	1130	1146	1130
	14	315	750	133.5	413	6.4	635	16-61	1257	1276	1257
	16	360	825	146.5	470	6.4	704.8	16-67	1384	1407	1384
	18	/	915	162	533	6.4	774.7	16-74	/	/	/
20	/	985	178	584	6.4	831.8	16-80	/	/	/	
24	/	1170	203.5	692	6.4	990.6	16-93	/	/	/	
2500Lb	1/2	13	133	30.5	35	6.4	88.9	4-22	264	264	264
	3/4	19	140	32	43	6.4	95.3	4-22	273	273	273
	1	25	159	35.5	51	6.4	108	4-26	308	308	308
	1 1/4	32	184	38.5	64	6.4	130	4-29	349	352	349
	1 1/2	38	203	44.5	73	6.4	146.1	4-32	384	387	384
	2	42	235	50.8	92	6.4	171.5	8-29	451	454	451
	2 1/2	52	267	57.2	105	6.4	196.9	8-32	508	514	508
	3	62	305	66.6	127	6.4	228.6	8-35	578	584	578
	4	87	356	76.2	157	6.4	273.1	8-41	673	683	673
	5	100	419	92	186	6.4	323.9	8-48	794	807	794
	6	131	483	108	216	6.4	368.3	8-54	914	927	914
	8	179	553	127	270	6.4	438.2	12-54	1022	1038	1022
	10	223	673	165.1	324	6.4	539.8	12-67	1270	1292	1270
	12	265	762	184.2	381	6.4	619.3	12-73	1422	1445	1422

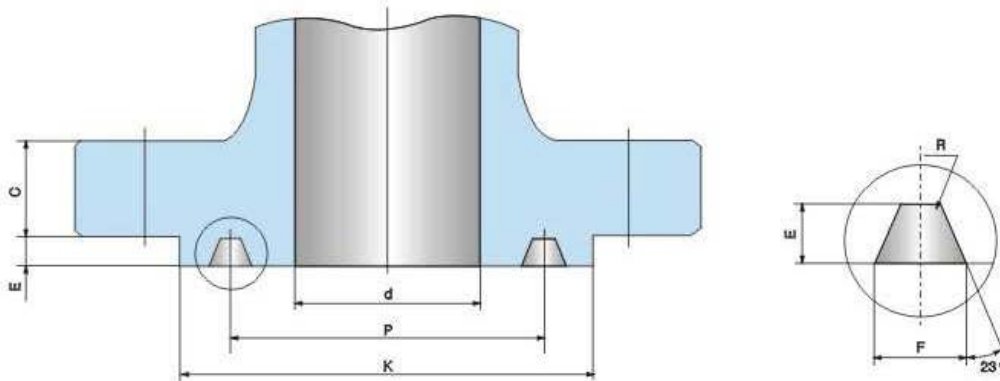

◆ ASME B16.5-2003 Flange Size of Ring Joint Sealing Surface (RTJ,RJ)

CLASS	NSP	Channel Diameter d	Ring Number	Pitch Diameter P		Groove Depth E		Groove Width F		Bottom of the Channel Radius R	Protuberant Part Diameter K	Thickness of the Flange C
				in	mm	in	mm	in	mm			
150Lb	1/2	13	/	/	/	/	/	/	/	/	/	/
	3/4	19	/	/	/	/	/	/	/	/	/	/
	1	25	R15	1.875	47.625	0.25	6.35	0.344	8.74	0.8	63.5	12
	1 1/4	32	R17	2.25	57.15	0.25	6.35	0.344	8.74	0.8	73.2	13
	1 1/2	38	R19	2.562	65.075	0.25	6.35	0.344	8.74	0.8	82.6	15
	2	49	R22	3.25	82.55	0.25	6.35	0.344	8.74	0.8	101.6	16
	2 1/2	62	R25	4	101.6	0.25	6.35	0.344	8.74	0.8	120.7	18
	3	74	R29	4.5	114.3	0.25	6.35	0.344	8.74	0.8	133.4	19
	4	100	R36	5.875	149.23	0.25	6.35	0.344	8.74	0.8	171.5	24
	5	127	R40	6.75	171.45	0.25	6.35	0.344	8.74	0.8	193.5	24
	6	150	R43	7.625	193.68	0.25	6.35	0.344	8.74	0.8	218.9	26
	8	201	R48	9.75	247.65	0.25	6.35	0.344	8.74	0.8	273.1	29
	10	252	R52	12	304.8	0.25	6.35	0.344	8.74	0.8	330.2	31
	12	303	R56	15	381	0.25	6.35	0.344	8.74	0.8	406.4	32
	14	334	R59	15.625	396.88	0.25	6.35	0.344	8.74	0.8	425.5	35
	16	385	R64	17.875	454.03	0.25	6.35	0.344	8.74	0.8	482.6	37
	18	436	R68	20.375	517.53	0.25	6.35	0.344	8.74	0.8	546.1	40
	20	487	R72	22	558.8	0.25	6.35	0.344	8.74	0.8	596.9	43
24	589	R76	26.5	673.1	0.25	6.35	0.344	8.74	0.8	711.2	48	

◆ ASME B16.5-2003 Flange Size of Ring Joint Sealing Surface (RTJ,RJ)

CLASS	NSP	Channel Diameter d	Ring Number	Pitch Diameter P		Groove Depth E		Groove Width F		Bottom of the Channel Radius R	Protuberant Part Diameter K	Thickness of the Flange C
				in	mm	in	mm	in	mm			
300Lb	1/2	13	R11	1.344	34.138	0.219	5.56	0.281	7.14	0.8	50.8	15
	3/4	19	R13	1.688	42.875	0.25	6.35	0.344	8.74	0.8	63.5	16
	1	25	R16	2	50.8	0.25	6.35	0.344	8.74	0.8	69.9	18
	1 1/4	32	R18	2.375	60.325	0.25	6.35	0.344	8.74	0.8	79.2	19
	1 1/2	38	R20	2.688	68.275	0.25	6.35	0.344	8.74	0.8	90.4	21
	2	49	R23	3.25	82.55	0.312	7.92	0.469	11.91	0.8	108.0	23
	2 1/2	62	R26	4	101.6	0.312	7.92	0.469	11.91	0.8	127.0	26
	3	74	R31	4.875	123.83	0.312	7.92	0.469	11.91	0.8	146.1	29
	4	100	R37	5.875	149.23	0.312	7.92	0.469	11.91	0.8	174.8	32
	5	127	R41	7.125	180.98	0.312	7.92	0.469	11.91	0.8	209.6	35
	6	150	R45	8.312	211.12	0.312	7.92	0.469	11.91	0.8	241.3	37
	8	201	R49	10.625	269.88	0.312	7.92	0.469	11.91	0.8	301.8	42
	10	252	R53	12.75	323.85	0.312	7.92	0.469	11.91	0.8	355.6	48
	12	303	R57	15	381	0.312	7.92	0.469	11.91	0.8	412.8	51
	14	334	R60	16.5	419.1	0.312	7.92	0.469	11.91	0.8	457.2	54
	16	385	R65	18.5	469.9	0.312	7.92	0.469	11.91	0.8	508.0	58
	18	436	R69	21	533.4	0.312	7.92	0.469	11.91	0.8	574.5	61
20	487	R73	23	584.2	0.375	9.53	0.531	13.49	1.5	635.0	64	
24	589	R77	27.25	692.15	0.438	11.13	0.656	16.66	1.5	749.3	70	
600Lb	1/2	13	R11	1.344	34.138	0.219	5.56	0.281	7.14	0.8	50.8	15
	3/4	19	R13	1.688	42.875	0.25	6.35	0.344	8.74	0.8	63.5	16
	1	25	R16	2	50.8	0.25	6.35	0.344	8.74	0.8	69.9	18
	1 1/4	32	R18	2.375	60.325	0.25	6.35	0.344	8.74	0.8	79.2	21
	1 1/2	38	R20	2.688	68.275	0.25	6.35	0.344	8.74	0.8	90.4	23
	2	49	R23	3.25	82.55	0.312	7.92	0.469	11.91	0.8	108.0	26
	2 1/2	62	R26	4	101.6	0.312	7.92	0.469	11.91	0.8	127.0	29
	3	74	R31	4.875	123.83	0.312	7.92	0.469	11.91	0.8	146.1	32
	4	100	R37	5.875	149.23	0.312	7.92	0.469	11.91	0.8	174.8	38
	5	127	R41	7.125	180.98	0.312	7.92	0.469	11.91	0.8	209.6	45
	6	150	R45	8.312	211.12	0.312	7.92	0.469	11.91	0.8	241.3	48
	8	201	R49	10.625	269.88	0.312	7.92	0.469	11.91	0.8	301.8	56
	10	252	R53	12.75	323.85	0.312	7.92	0.469	11.91	0.8	355.6	64
	12	303	R57	15	381	0.312	7.92	0.469	11.91	0.8	412.8	67
	14	334	R60	16.5	419.1	0.312	7.92	0.469	11.91	0.8	457.2	70
	16	385	R65	18.5	469.9	0.312	7.92	0.469	11.91	0.8	508.0	77
	18	436	R69	21	533.4	0.312	7.92	0.469	11.91	0.8	574.5	83
20	487	R73	23	584.2	0.375	9.53	0.531	13.49	1.5	635.0	89	
24	589	R77	27.25	692.15	0.438	11.13	0.656	16.66	1.5	749.3	102	

◆ ASME B16.5-2003 Flange Size of Ring Joint Sealing Surface (RTJ,RJ)

CLASS	NSP	Channel Diameter d	Ring Number	Pitch Diameter P		Groove Depth E		Groove Width F		Bottom of the Channel Radius R	Protuberant Part Diameter K	Thickness of the Flange C
				in	mm	in	mm	in	mm			
900Lb	1/2	13	R12	1.562	39.675	0.25	6.35	0.344	8.74	0.8	60.5	22.5
	3/4	19	R14	1.75	44.45	0.25	6.35	0.344	8.74	0.8	66.5	25.5
	1	25	R16	2	50.8	0.25	6.35	0.344	8.74	0.8	71.4	29
	1 1/4	32	R18	2.375	60.325	0.25	6.35	0.344	8.74	0.8	81.0	29
	1 1/2	38	R20	2.688	68.275	0.25	6.35	0.344	8.74	0.8	91.9	32
	2	49	R24	3.75	95.25	0.312	7.92	0.469	11.91	0.8	124.0	38.5
	2 1/2	62	R27	4.25	107.95	0.312	7.92	0.469	11.91	0.8	136.7	41.5
	3	74	R31	4.875	123.83	0.312	7.92	0.469	11.91	0.8	155.4	38.5
	4	100	R37	5.875	149.23	0.312	7.92	0.469	11.91	0.8	180.8	44.5
	5	127	R41	7.125	180.98	0.312	7.92	0.469	11.91	0.8	215.9	51
	6	150	R45	8.312	211.12	0.312	7.92	0.469	11.91	0.8	241.3	56
	8	201	R49	10.625	269.88	0.312	7.92	0.469	11.91	0.8	307.8	63.5
	10	252	R53	12.75	323.85	0.312	7.92	0.469	11.91	0.8	362.0	70
	12	303	R57	15	381	0.312	7.92	0.469	11.91	0.8	419.1	79.5
	14	322	R62	16.5	419.1	0.438	11.13	0.656	16.66	1.5	466.9	86
	16	373	R66	18.5	469.9	0.438	11.13	0.656	16.66	1.5	523.7	89
18	423	R70	21	533.4	0.5	12.70	0.781	19.84	1.5	593.9	102	
20	471	R74	23	584.2	0.5	12.70	0.781	19.84	1.5	647.7	108	
24	570	R78	27.25	692.15	0.625	15.88	1.062	26.97	2.3	771.7	140	
1500Lb	1/2	13	R12	1.562	39.675	0.25	6.35	0.344	8.74	0.8	60.5	22.5
	3/4	19	R14	1.75	44.45	0.25	6.35	0.344	8.74	0.8	66.5	25.5
	1	25	R16	2	50.8	0.25	6.35	0.344	8.74	0.8	71.4	29
	1 1/4	32	R18	2.375	60.325	0.25	6.35	0.344	8.74	0.8	81.0	29
	1 1/2	38	R20	2.688	68.275	0.25	6.35	0.344	8.74	0.8	91.9	32
	2	49	R24	3.75	95.25	0.312	7.92	0.469	11.91	0.8	124.0	38.5
	2 1/2	62	R27	4.25	107.95	0.312	7.92	0.469	11.91	0.8	136.7	41.5
	3	74	R35	5.375	136.53	0.312	7.92	0.469	11.91	0.8	168.1	48
	4	100	R39	6.375	161.93	0.312	7.92	0.469	11.91	0.8	193.5	54
	5	125	R44	7.625	193.68	0.312	7.92	0.469	11.91	0.8	228.6	73.5
	6	144	R46	8.312	211.12	0.375	9.53	0.531	13.49	1.5	247.7	83
	8	192	R50	10.625	269.88	0.438	11.13	0.656	16.66	1.5	317.5	92.9
	10	239	R54	12.75	323.85	0.438	11.13	0.656	16.66	1.5	371.3	108
	12	287	R58	15	381	0.562	14.27	0.906	23.01	1.5	438.2	124
	14	315	R63	16.5	419.1	0.625	15.88	1.062	26.97	2.3	489.0	133.5
	16	360	R67	18.5	469.9	0.688	17.48	1.188	30.18	2.3	546.1	146.5
18	/	R71	21	533.4	0.688	17.48	1.188	30.18	2.3	612.6	162	
20	/	R75	23	584.2	0.688	17.48	1.312	33.32	2.3	673.1	178	
24	/	R79	27.25	692.15	0.812	20.62	1.438	36.53	2.3	793.8	203.5	
2500Lb	1/2	13	R13	1.688	42.875	0.25	6.35	0.344	8.74	0.8	65.0	30.5
	3/4	19	R16	2	50.8	0.25	6.35	0.344	8.74	0.8	73.2	32
	1	25	R18	2.375	60.325	0.25	6.35	0.344	8.74	0.8	82.6	35.5
	1 1/4	32	R21	2.844	72.238	0.312	7.92	0.469	11.91	0.8	101.6	38.5
	1 1/2	38	R23	3.25	82.55	0.312	7.92	0.469	11.91	0.8	114.3	44.5
	2	42	R26	4	101.6	0.312	7.92	0.469	11.91	0.8	133.4	50.8
	2 1/2	52	R28	4.375	111.13	0.375	9.53	0.531	13.49	1.5	149.4	57.2
	3	62	R32	5	127	0.375	9.53	0.531	13.49	1.5	168.1	66.6
	4	87	R38	6.188	157.18	0.438	11.13	0.656	16.66	1.5	203.2	76.2
	5	100	R42	7.5	190.5	0.5	12.70	0.781	19.84	1.5	241.3	92
	6	131	R47	9	228.6	0.5	12.70	0.781	19.84	1.5	279.4	108
	8	179	R51	11	279.4	0.562	14.27	0.906	23.01	1.5	339.9	127
10	223	R55	13.5	342.9	0.688	17.48	1.188	30.18	2.3	425.5	165.1	
12	265	R60	16	406.4	0.688	17.48	1.312	33.32	2.3	495.3	184.2	

Cv Value

◆ **Ball Valve Flow Coefficient (Cv)**

Size (Inch)	Cv					
	Class 150	Class 300	Class 600	Class 900	Class 1500	Class 2500
1/2	24	24	24	24	24	24
3/4	53	53	53	53	53	53
1	92	92	92	92	92	92
1 1/2	211	211	211	211	211	211
2	381	381	381	381	381	283
3	845	845	845	845	845	600
4	1523	1523	1523	1523	1523	1160
6	3381	3381	3381	3381	3120	2590
8	6031	6031	6031	6031	5508	4795
10	9442	9442	9442	9442	8500	7410
12	13614	13614	13614	13614	12223	10433
14	16621	16621	16621	15363	14800	/
16	21920	21920	21920	20581	19178	/
18	28076	28076	28076	26435	24243	/
20	34995	34995	34995	32743	30565	/
22	42676	42676	42676	4184	35860	/
24	51117	51117	51117	47884	41733	/
26	59012	59012	59012	56076	/	/
28	68872	68872	68872	65110	/	/
30	79493	79493	79493	74610	/	/
32	89268	89268	89268	84977	/	/
34	101307	101307	101307	96020	/	/
36	112306	112306	112306	107487	/	/
40	139982	139982	139989	/	/	/

Note:

- 1.The flow coefficient *CV* of a valve is the flow rate in Gallons/minute of 60° F water through a fully opened valve, at a pressure drop of 1 PSI across the valve.
- 2.All the ball valves are full bore.

◆ **Spheroid Top Coat Operating Instructions**

Matrix Material	Metallic Material					
Coating Material	Tungsten carbide	Nichrome chromic carbide	N:60	Inconel 625	Stellite6	Stellite20
Hardness	HV800-1300° HRC68-72°	HV600-950° HRC55-68°	HV600-700° HRC50-60°	HV380-420° HRC38-40°	HV380-430° HRC38-43°	HV580-620° HRC50-56°
Applicable Temperature	≤450°C	≤880°C	≤450°C	≤660°C	≤680°C	≤680°C
Coating Thickness	0.15-1mm					
Coating Bonding Strength	70MPa					
Applicable Parts	Body, Seat, Channel	Body, Seat, Channel	Body, Seat, Channel	Body, Seat, Channel, Stem	Seat, Channel, Stem	Seat, Channel, Stem
Applicable Medium	Generally used for ore. Coal, cement, silica fume, sewage. Gas, steam, chemical, gas, water and some with crystal particles of mining. Aqueous solution and moisture corrosion, has a good microstructure and high bonding strength and smoothness, a higher corrosion resistance, and to replace hard chrome.					
Use Merit	Chromium carbide nickel chromium temperature880°C , hardness55-68HRC.The material is dense duplicated and corrosion resistant, good resistance to cavitation , hot gas corrosion resistance, low friction properties, corrosion resistant and high temperature oxidation of gas.					

Torque Value

◆ Floating Ball Valve Design Torque

Size (inch)	Design Torque (N.m)				
	Class 150	Class 300	Class 600	Class 900	Class 1500
1/2	12	17	30	38	51
3/4	14	23	38	56	71
1	27	48	66	98	130
1-1/2	55	89	120	189	238
2	75	100	160	240	350
2-1/2	125	141	233	390	550
3	162	216	308	610	980
4	234	476	635	/	/
5	546	910	/	/	/
6	804	1338	1944	/	/
8	1410	3100	/	/	/
10	2600	5400	/	/	/

Notes:

1. All valves are in normal temperature, with PTEE seat for Class 150~300 and Nylon seat for Class 600~1500.
2. For cryogenic ball valve, torque will be 2~2.5 times the above torque.
3. Torque shown in this table is to be used as a guide for actuator selection. A safety factor of 1.5 is recommended for actuator sizing.
4. Torque may change according to different medium and trim material.

◆ Operation Torque

Type	Size		PN 16	PN 25	PN 40	PN 63	PN 100	PN 160	Class 150 PN 20	Class 300 PN 50	Class 600 PN 100	Class 900 PN 150	Class 1500 PN 260	Class 2500 PN 420
	NPS	DN												
Metal to metal sealed floating ball valves	1/2	15	20	27	33	50	57	82	24	35	62	80	120	190
	3/4	20	30	40	49	66	80	117	35	57	85	115	170	270
	1	25	45	60	76	116	132	220	53	88	145	215	350	580
	1 1/4	32	70	92	102	165	198	330	80	117	210	320	520	865
	1 1/2	40	120	132	147	232	295	395	127	165	320	380	620	1050
	2	50	145	195	240	280	350	550	160	255	370	540	760	1280
	2 1/2	65	235	300	315	450	600	940	285	355	640	900	1370	2170
	3	80	340	470	540	720	1120	1780	410	580	1250	1720	2590	4100
	4	100	480	680	810	1160	1650	2950	530	1000	1780	2870	3850	6200
	5	125	750	1080	1650	1850	2800	4350	/	/	/	/	/	/
6	150	1470	1850	2700	3750	3620	5820	1550	3000	3800	5770	8800	14000	
8	200	2320	2820	3380	5070	6800	12900	2580	3820	7200	12550	19100	/	
10	250	3780	5350	6470	/	/	/	4290	7200	/	/	/	/	
Metal to metal sealed trunnion ball valves	2	50	105	140	170	207	240	370	115	180	245	350	510	860
	2 1/2	65	170	220	225	320	410	620	205	255	420	600	915	1450
	3	80	245	335	390	520	790	1200	295	410	840	1150	1720	2760
	4	100	345	485	580	830	1150	1750	380	690	1190	1650	2590	4140
	5	125	520	780	980	1200	1870	2950	/	/	/	/	/	/
	6	150	940	1150	1280	1800	2300	4020	970	1400	2400	3850	5860	9350
	8	200	1550	1900	2250	3900	5800	8700	1720	2550	5980	8500	12770	20350
	10	250	2590	3570	4310	6000	8000	14950	2860	4850	8400	14220	21390	34100
	12	300	4000	5250	6200	8700	11900	22250	4200	7000	12600	21100	31400	51050
	14	350	6250	7870	8400	11700	16200	/	6600	9300	17400	28200	49000	/
	16	400	8100	10040	12900	18200	21300	/	8970	14400	22500	39500	59000	/
	18	450	10500	13800	16500	/	/	/	11100	18300	33680	56000	/	/
	20	500	13500	18000	20400	/	/	/	14400	22500	50400	71200	/	/
	22	550	/	/	/	/	/	/	17080	28200	60800	/	/	/
24	600	19500	28200	32350	/	/	/	22580	38800	73600	132800	/	/	

Notes:

1. The torque in the table is open torque under Max. Differential pressure, which is only for reference to aid in drive selection.
2. Choose the actuator with safety coefficient more than 1.25 times.
3. Additional torque maybe required, dependent on the nature of the medium, inner parts and on/off speed.
4. For larger torque requirement, please contact SKVAL.

Torque Value & Mounting Flange Dimensions

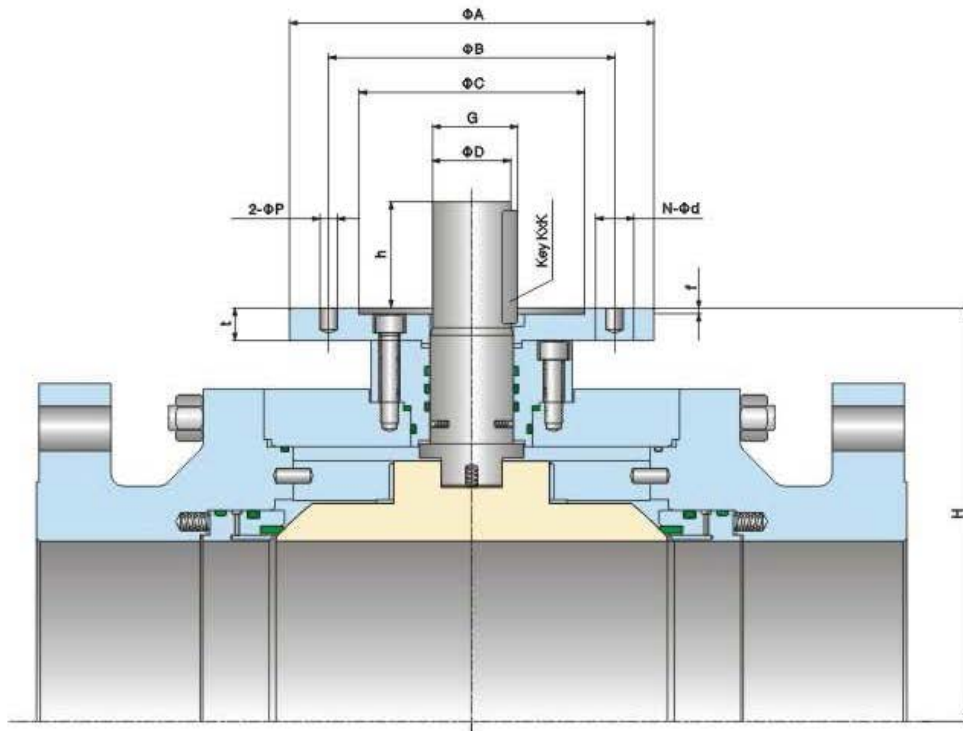

Size Inch	Class	Torque N.m	Flange Dimensions mm							ISO5211 Flange Number	Key Size KxK mm	G mm	D mm	h mm	H mm
			A	B	C	f	t	n-d	P						
2*1 1/2	150	42	90	70	55	3	12	4-9	6	F07	6×6	25	22	25	95
	300	66	90	70	55	3	12	4-9	6	F07	6×6	25	22	25	95
	600	102	90	70	55	3	12	4-9	6	F07	6×6	25	22	25	95
	900	142	90	70	55	3	12	4-9	6	F07	6×6	25	22	25	100
	1500	241	90	70	55	3	15	4-9	6	F07	6×6	25	22	25	100
	2500	423	125	102	70	3	15	4-11	8	F10	8×8	32	28	30	115
2	150	76	90	70	55	3	12	4-9	6	F07	6×6	25	22	25	103
	300	91	90	70	55	3	12	4-9	6	F07	6×6	25	22	25	103
	600	143	90	70	55	3	12	4-9	6	F07	6×6	25	22	25	102
	900	231	125	102	70	3	17	4-11	8	F10	8×8	32	28	30	117
	1500	349	125	102	70	3	17	4-11	8	F10	8×8	32	28	30	117
	2500	798	150	125	85	3	20	4-13	10	F12	10×10	41	36	55	141
3	150	121	125	102	70	3	15	4-11	8	F10	8×8	32	28	30	129
	300	159	125	102	70	3	15	4-11	8	F10	8×8	32	28	30	129
	600	269	125	102	70	3	15	4-11	8	F10	8×8	32	28	30	132
	900	524	150	125	85	3	18	4-13	10	F12	10×10	41	36	55	140
	1500	887	150	125	85	3	18	4-13	10	F12	10×10	41	36	55	153
	2500	1583	175	140	100	4	24	4-18	10	F14	12×12	51	45	65	169
4	150	179	125	102	70	3	15	4-11	8	F10	8×8	32	28	30	150
	300	355	125	102	70	3	15	4-11	8	F10	8×8	32	28	30	150
	600	670	150	125	85	3	18	4-13	10	F12	10×10	41	36	55	160
	900	875	175	140	100	4	20	4-18	10	F14	12×12	51	45	65	172
	1500	1351	210	165	130	5	24	4-22	12	F16	14×14	57	50	75	193
	2500	2111	210	165	130	5	26	4-22	12	F16	14×14	62	55	80	205

Size inch	Class	Totque N.m	Flange Dimensions mm							ISO5211 Flange number	Key Size KxK mm	G mm	D mm	h mm	H mm
			A	B	C	f	t	n-d	P						
6	150	631	150	125	85	3	18	4-13	10	F12	10×10	41	36	55	188
	300	854	150	125	85	3	18	4-13	10	F12	10×10	41	36	55	188
	600	1609	175	140	100	4	20	4-18	10	F14	12×12	51	45	65	208
	900	1927	210	165	130	5	22	4-22	12	F16	14×14	62	55	80	215
	1500	3512	210	165	130	5	24	4-22	14	F16	16×16	68	60	90	235
	2500	5454	300	254	200	5	28	8-18	16	F25	16×16	73	65	95	270
8	150	987	210	165	130	5	20	4-22	10	F16	12×12	51	45	60	233
	300	1562	210	165	130	5	20	4-22	10	F16	12×12	51	45	60	233
	600	2501	210	165	130	5	22	4-22	12	F16	14×14	62	55	80	249
	900	4012	210	165	130	5	22	4-22	14	F16	16×16	68	60	90	266
	1500	6513	300	254	200	5	28	8-18	16	F25	18×18	79	70	105	285
	2500	8495	300	254	200	5	32	8-18	16	F25	18×18	84	75	110	355
10	150	1321	210	165	130	5	20	4-22	12	F16	14×14	62	55	80	278
	300	2304	210	165	130	5	20	4-22	12	F16	14×14	62	55	80	278
	600	3405	210	165	130	5	24	4-22	14	F16	16×16	68	60	90	300
	900	5017	300	254	200	5	25	8-18	16	F25	18×18	79	70	105	315
	1500	7996	300	254	200	5	28	8-18	16	F25	18×18	84	75	110	345
	2500	13148	300	254	200	5	32	8-18	16	F25	20×20	95	85	125	412
12	150	1650	210	165	130	5	24	4-22	14	F16	16×16	68	60	90	318
	300	3041	210	165	130	5	24	4-22	14	F16	16×16	68	60	90	320
	600	4507	300	254	200	5	25	8-18	16	F25	18×18	79	70	105	345
	900	6512	300	254	200	5	28	8-18	16	F25	18×18	84	75	110	360
	1500	10078	300	254	200	5	30	8-18	16	F25	20×20	95	85	125	408
	2500	18007	350	298	260	5	38	8-22	20	F30	24×24	107	95	140	478
14	150	2415	300	254	200	5	26	8-18	16	F25	16×16	73	65	95	353
	300	4019	300	254	200	5	26	8-18	16	F25	16×16	73	65	95	360
	600	6578	300	254	200	5	28	8-18	16	F25	18×18	84	75	110	376
	900	9489	300	254	200	5	28	8-18	16	F25	20×20	95	85	125	388
	1500	14860	300	254	200	5	35	8-18	16	F25	24×24	107	95	140	448
16	150	3314	300	254	200	5	28	8-18	16	F25	18×18	84	75	110	393
	300	5350	300	254	200	5	28	8-18	16	F25	18×18	84	75	110	406
	600	9025	300	254	200	5	28	8-18	16	F25	20×20	95	85	125	414
	900	12877	300	254	200	5	30	8-18	16	F25	24×24	107	95	140	442
	1500	21857	350	298	230	5	35	8-22	20	F30	28×28	119	105	155	490
18	150	5148	300	254	200	5	28	8-18	16	F25	18×18	84	75	110	435
	300	8375	300	254	200	5	28	8-18	16	F25	20×20	95	85	125	448
	600	13493	300	254	200	5	30	8-18	16	F25	24×24	107	95	140	458
	900	18975	350	298	230	5	32	8-22	20	F30	28×28	119	105	165	487
	1500	29032	350	298	230	5	38	8-22	20	F30	32×32	136	120	180	545
20	150	6425	300	254	200	5	30	8-18	16	F25	20×20	90	80	120	477
	300	10987	300	254	200	5	30	8-18	16	F25	24×24	107	95	140	485
	600	18502	350	298	230	5	32	8-22	20	F30	28×28	119	105	165	510
	900	26048	350	298	230	5	38	8-22	20	F30	32×32	136	120	180	530
	1500	40907	415	356	260	5	42	8-33	28	F35	36×36	158	140	210	580
24	150	12379	300	254	200	5	32	8-18	16	F25	24×24	102	90	135	562
	300	19384	350	298	230	5	32	8-22	20	F30	28×28	124	110	165	565
	600	29546	350	298	230	5	38	8-22	20	F30	32×32	136	120	180	602
	900	42379	415	356	260	5	42	8-33	28	F35	36×36	158	140	210	630
	1500	65223	475	406	300	8	48	8-39	28	F40	40×40	180	160	240	730

Notes:

1. The torque is for valves with PTEE seat or Nylon seat as per different size/class selection.
2. The torque value shown in above table is the valve torque at normal temperature, for sizing;
 - a. If medium temperature is -10°C~40°C, the output torque of actuator should be 1.5 times the valve torque;
 - b. If medium temperature is less than -10°C, the output torque of actuator should be 2 or 2.5 times the valve torque.

Soft Materials Data

◆ Specifications for Seat Materials

	PTFE	RPTFE	Molon(Nylon+MoS2)	PEEK
Tensile Strength (MPa)	24.8	25.4	75~100	91
Compressive Strength (MPa)	35	52	100~140	137
Elongation (%)	250	120	10~30	50
Hardness (SH.A)	56	60	78	82
Water Absorption (%)	<0.01	<0.01	0.7	0.12
Specific Gravity (G/cm ³)	2.2	2.2	1.2	1.35
Temperature Range (°F)	-300~400	-150~425	-40~300	-150~500
Pressure Rating (Class)	150~600	150~600	150~1500	150~2500
Service Application	Chemical & Cryogenic	Chemical & Cryogenic	High Pressure & Low Temperature	High Pressure & High Temperature
	Nylon1010	Nylon12	Devlon V	Delrin
Tensile Strength (MPa)	55	60	80	68
Compressive Strength (MPa)	70	79	140	110
Elongation (%)	150	200	5.37	220
Hardness (SH.A)	70	75	78	78
Water Absorption (%)	0.3	0.2	0.1	0.2
Specific Gravity (G/cm ³)	1.04	1.01	1.14	1.41
Temperature Range (°F)	-40~200	-58~250	-150~300	-58~230
Pressure Rating (Class)	600~1500	600~1500	150~1500	150~1500
Service Application	High Pressure & Low Temperature	High Pressure & Low Temperature	High Pressure & Low Temperature	High Pressure & Low Temperature

◆ Specificationd for Seal Materials

Service Application	Viton A	NBR	Viton B	HNBR(HSN)	Viton AED
Temperature range (°F)	-20~400	-50~250	-20~400	-40~320	-20~480
Hardness (SH.A)	70	70	70	80	90
Specific Gravity (G/cm ³)	1.85	1.2	1.85	1.33	1.9
Service Application	Petroleum Oils, Gasoline, Transmission Fluid	Petroleum Oils, Water, Hydraulic Oils	Mineral Acid, Steam, MTBE	Petroleum Oils, H2S & CO2 Anti-Explosive Decompression	Petroleum Oils, H2S & CO2 Anti-Explosive Decompression

◆ Specifications for Gasket Materials

	Flexible Graphite	Spiral Wound 316+Graphite	PTFE	Spiral Wound Monel+PTFE
Temperature Range (°F)	-300~900	-300~900	-300~400	-300~400
PH	0~14	0~14	0~14	0~14
Service Application	Fire-safe	Fire-safe	Cryogenic, High Corrosive	High Corrosive

IMCOPIPES FZ LLC

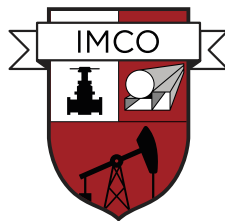

We serve the world

IMCOPIPES FZ LLC, Compass Building, Al Shohada Road,
Al Hamra Industrial Zone, Ras Al Khaimah, United Arab Emirates
VAT No.: 104379977200003

IMCO TRADING GROUP LTD, Suite 2, 179 North End Road, London, W14 9NL, United Kingdom.
VAT No.: GB 422177419

Tel: +44 (0) 208 088 4690

E-mail: sales@imcopipes.com

